

FLUID - DEFINITION

Introduction: In general matter can be distinguished by the physical forms known as solid, liquid, and gas. The liquid and gaseous phases are usually combined and given a common name of fluid. Solids differ from fluids on account of their molecular structure (spacing of molecules and ease with which they can move). The intermolecular forces are large in a solid, smaller in a liquid and extremely small in gas.

Fluid mechanics is the study of fluids at rest or in motion. It has traditionally been applied in such area as the design of pumps, compressor, design of dam and canal, design of piping and ducting in chemical plants, the aerodynamics of airplanes and automobiles. In recent years fluid mechanics is truly a ‘high-tech’ discipline and many exciting areas have been developed like the aerodynamics of multistory buildings, fluid mechanics of atmosphere, sports, and micro fluids.

Definition of Fluid: A *fluid* is a substance which deforms continuously under the action of shearing forces, however small they may be. Conversely, it follows that: If a fluid is at rest, there can be no shearing forces acting and, therefore, all forces in the fluid must be perpendicular to the planes upon which they act.

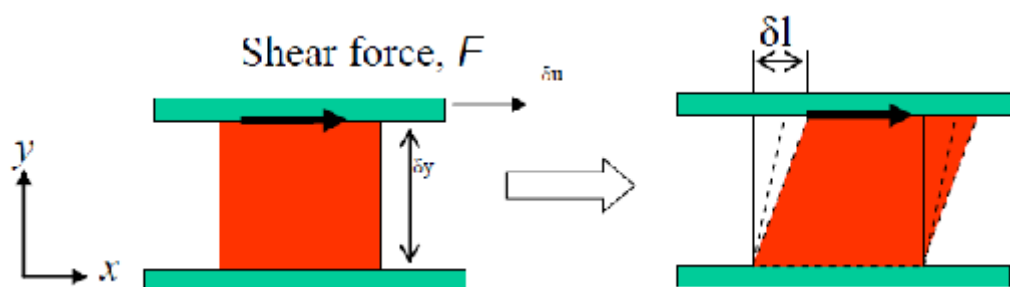

Figure 1.1.1 Deformation of a Solid and a Fluid Exposed to an applied Force

[Source: “https://en.wikiversity.org/wiki/Fluid_Mechanics_for_Mechanical_Engineers/Introduction”]

Fluid deforms continuously under the action of a shear force

$$\tau_{yx} = \frac{dF_x}{dA_y} = f(\text{Deformation Rate})$$

Shear stress in a moving fluid:

Although there can be no shear stress in a fluid at rest, shear stresses are developed when the fluid is in motion, if the particles of the fluid move relative to each other so that they have different velocities, causing the original shape of the fluid to become distorted. If, on the other hand, the velocity of the fluid is same at every point, no

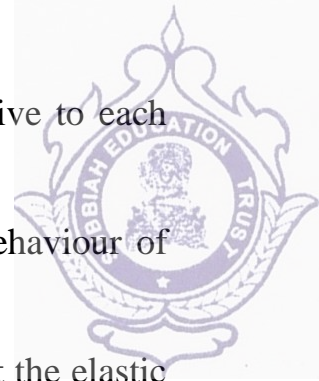

shear stresses will be produced, since the fluid particles are at rest relative to each other.

Differences between solids and fluids: The differences between the behaviour of solids and fluids under an applied force are as follows:

- i. For a solid, the strain is a function of the applied stress, providing that the elastic limit is not exceeded. For a fluid, the rate of strain is proportional to the applied stress.
- ii. The strain in a solid is independent of the time over which the force is applied and, if the elastic limit is not exceeded, the deformation disappears when the force is removed. A fluid continues to flow as long as the force is applied and will not recover its original form when the force is removed.

Differences between liquids and gases:

Although liquids and gases both share the common characteristics of fluids, they have many distinctive characteristics of their own. A liquid is difficult to compress and, for many purposes, may be regarded as incompressible. A given mass of liquid occupies a fixed volume, irrespective of the size or shape of its container, and a free surface is formed if the volume of the container is greater than that of the liquid.

A gas is comparatively easy to compress (Fig.1). Changes of volume with pressure are large, cannot normally be neglected and are related to changes of temperature. A given mass of gas has no fixed volume and will expand continuously unless restrained by a containing vessel. It will completely fill any vessel in which it is placed and, therefore, does not form a free surface.

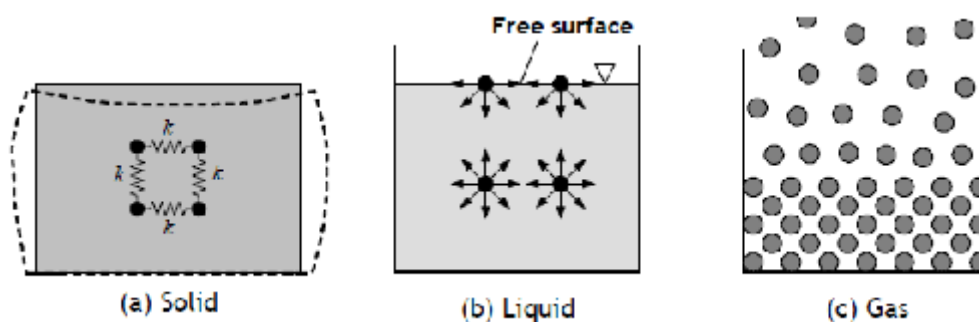
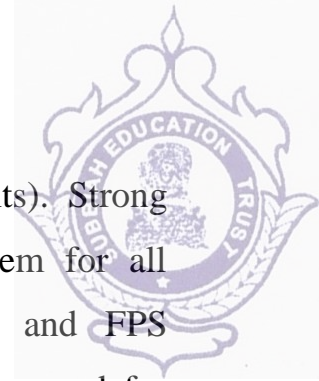

Figure 1.1.2 Comparison of Solid, Liquid and Gas

[Source: "https://en.wikiversity.org/wiki/Fluid_Mechanics_for_Mechanical_Engineers/Introduction"]



1.2 Systems of Units

The official International System of Units (System International Units). Strong efforts are underway for its universal adoption as the exclusive system for all engineering and science, but older systems, particularly the CGS and FPS engineering gravitational systems are still in use and probably will be around for some time. The chemical engineer finds many physiochemical data given in CGS units; that many calculations are most conveniently made in fps units; and that SI units are increasingly encountered in science and engineering. Thus it becomes necessary to be expert in the use of all three systems.

SI system:

Primary quantities:

<i>Quantity</i>	<i>Unit</i>
Mass in Kilogram	kg
Length in Meter	m
Time in Second	s or as sec
Temperature in Kelvin	K
Mole	mol

Derived quantities:

<i>Quantity</i>	<i>Unit</i>
Force in Newton (1 N = 1 kg.m/s ²)	N
Pressure in Pascal (1 Pa = 1 N/m ²)	N/m ²
Work, energy in Joule (1 J = 1 N.m)	J
Power in Watt (1 W = 1 J/s)	W

CGS Units:

The older centimeter-gram-second (CGS) system has the following units for derived quantities:

<i>Quantity</i>	<i>Unit</i>
Force in dyne (1 dyn = 1 g.cm/s ²)	dyn
Work, energy in erg (1 erg = 1 dyn.cm = 1 x 10 ⁻⁷ J)	erg
Heat Energy in calorie (1 cal = 4.184 J)	cal



Dimensions: Dimensions of the primary quantities:

<i>Fundamental dimension</i>	<i>Symbol</i>
Length	L
Mass	M
Time	t
Temperature	T

Dimensions of derived quantities can be expressed in terms of the fundamental dimensions.

<i>Quantity</i>	<i>Representative symbol</i>	<i>Dimensions</i>
Angular velocity	ω	t^{-1}
Area	A	L^2
Density	ρ	M/L^3
Force	F	ML/t^2
Kinematic viscosity	ν	L^2/t
Linear velocity	v	L/t

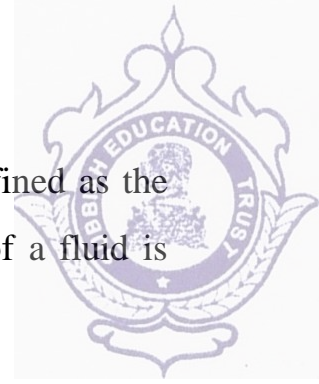

1.3 FLUID PROPERTIES:

1. Density or Mass density (ρ): Density or mass density of a fluid is defined as the ratio of the mass of a fluid to its volume. Thus mass per unit volume of a fluid is called density.

$$\therefore \rho = \frac{\text{Mass}}{\text{Volume}}$$

$$\rho = \frac{M}{V} \text{ or } \frac{dM}{dV}$$

The unit of density in S.I. unit is kg/m^3 . The value of density for water is 1000kg/m^3 . With the increase in temperature volume of fluid increases and hence mass density decreases in case of fluids as the pressure increases volume decreases and hence mass density increases.

2. Specific weight or weight density (γ): Specific weight or weight density of a fluid is the ratio between the weight of a fluid to its volume. The weight per unit volume of a fluid is called weight density.

$$\therefore \gamma = \frac{\text{Weight}}{\text{Volume}} = \frac{W}{V} \text{ or } \frac{dW}{dV}$$

The unit of specific weight in S.I. units is N/m^3 . The value of specific weight or weight density of water is 9810N/m^3 .

With increase in temperature volume increases and hence specific weight decreases.

With increases in pressure volume decreases and hence specific weight increases.

Note: Relationship between mass density and weight density:

$$\text{We have } \gamma = \frac{\text{Weight}}{\text{Volume}}$$

$$\gamma = \frac{\text{mass} \times g}{\text{Volume}}$$

$$\gamma = \rho \times g$$



3. Specific Volume (∇): Specific volume of a fluid is defined as the volume of a fluid occupied by a unit mass or volume per unit mass of a fluid.

$$\therefore \nabla = \frac{\text{Volume}}{\text{mass}} = \frac{V}{M} \text{ or } \frac{dV}{dM}$$

As the temperature increases volume increases and hence specific volume increases.

As the pressure increases volume decreases and hence specific volume decreases.

4. Specific Gravity (S): Specific gravity is defined as the ratio of the weight density of a fluid to the weight density of a standard fluid.

$$S = \frac{\rho_{\text{fluid}}}{\rho_{\text{standard fluid}}}$$

Unit: It is a dimensionless quantity and has no unit.

In case of liquids water at 4°C is considered as standard liquid. $\rho_{\text{water}} = 1000 \text{ kg/m}^3$

Problem 1: Calculate specific weight, mass density, specific volume and specific gravity of a liquid having a volume of 4m^3 and weighing 29.43 kN . Assume missing data suitably.

$\gamma = \frac{W}{V}$ $= \frac{29.43 \times 10^3}{4}$ $\gamma = 7357.58 \text{ N/m}^3$	$\gamma = ?$ $\rho = ?$ $\nabla = ?$ $S = ?$ $V = 4\text{m}^3$ $W = 29.43 \text{ kN}$ $= 29.43 \times 10^3 \text{ N}$
---	---

To find ρ - Method 1:

$$W = mg$$

$$29.43 \times 10^3 = m \times 9.81$$

$$m = 3000 \text{ kg}$$

$$\therefore \rho = \frac{m}{v} = \frac{3000}{4}$$

Method 2:

$$\gamma = \rho g$$

$$7357.5 = \rho \times 9.81$$

$$\rho = 750 \text{ kg/m}^3$$



$$\rho = 750 \text{ kg/m}^3$$

$$i) \nabla = \frac{V}{M}$$

$$= \frac{4}{3000}$$

$$\nabla = 1.33 \times 10^{-3} \text{ m}^3/\text{kg}$$

$$S = \frac{\gamma}{\gamma_{\text{Standard}}}$$

$$= \frac{7357.5}{9810} \quad \text{or}$$

$$S = 0.75$$

$$\rho = \frac{M}{V}$$

$$\nabla = \frac{V}{M}$$

$$\nabla = \frac{1}{\rho} = \frac{1}{750}$$

$$\nabla = 1.33 \times 10^{-3} \text{ m}^3/\text{kg}$$

$$S = \frac{\rho}{\rho_{\text{Standard}}}$$

$$S = \frac{750}{1000}$$

$$S = 0.75$$

Problem2: Calculate specific weight, density, specific volume and specific gravity and if one liter of Petrol weighs 6.867N.

$$\gamma = \frac{W}{V}$$

$$= \frac{6.867}{10^{-3}}$$

$$\gamma = 6867 \text{ N/m}^3$$

$$S = \frac{\gamma}{\gamma_{\text{Standard}}}$$

$$= \frac{6867}{9810}$$

$$S = 0.7$$

$$V = 1 \text{ Litre}$$

$$V = 10^{-3} \text{ m}^3$$

$$W = 6.867 \text{ N}$$

$$\rho = s \cdot g$$

$$6867 = \rho \times 9.81$$

$$\rho = 700 \text{ kg/m}^3$$



$$\begin{aligned} \nabla &= \frac{V}{M} \\ &= \frac{10^{-3}}{0.7} \end{aligned}$$

$$\nabla = 1.4 \times 10^{-3} \text{ m}^3 / \text{kg}$$

$$M = 6.867 \div 9.81$$

$$M = 0.7 \text{ kg}$$

Problem 3: Specific gravity of a liquid is 0.7 Find i) Mass density ii) specific weight. Also find the mass and weight of 10 Liters of liquid.

$$S = \frac{\gamma}{\gamma_{\text{Standard}}}$$

$$\gamma = \rho g$$

$$S = 0.7$$

$$V = ?$$

$$\rho = ?$$

$$0.7 = \frac{\gamma}{9810}$$

$$6867 = \rho \times 9.81$$

$$M = ?$$

$$W = ?$$

$$\gamma = 6867 \text{ N/m}^3$$

$$\rho = 700 \text{ kg/m}^3$$

$$V = 10 \text{ litre}$$

$$= 10 \times 10^{-3} \text{ m}^3$$

$$S = \frac{\rho}{\rho_{\text{Standard}}}$$

$$0.7 = \frac{\rho}{1000}$$

$$\rho = 700 \text{ kg/m}^3$$

$$\rho = \frac{M}{V}$$

$$700 = \frac{M}{10 \times 10^{-3}}$$

$$\rho = \frac{M}{V}$$

$$700 = \frac{M}{10 \times 10^{-3}}$$

$$M = 7 \text{ kg}$$



5. Viscosity: Viscosity is the property by virtue of which fluid offers resistance against the flow or shear deformation. In other words, it is the reluctance of the fluid to flow. Viscous force is that force of resistance offered by a layer of fluid for the motion of another layer over it.

In case of liquids, viscosity is due to cohesive force between the molecules of adjacent layers of liquid. In case of gases, molecular activity between adjacent layers is the cause of viscosity.

Newton's law of viscosity:

Let us consider a liquid between the fixed plate and the movable plate at a distance 'Y' apart, 'A' is the contact area (Wetted area) of the movable plate, 'F' is the force required to move the plate with a velocity 'U' According to Newton's law shear stress is proportional to shear strain.

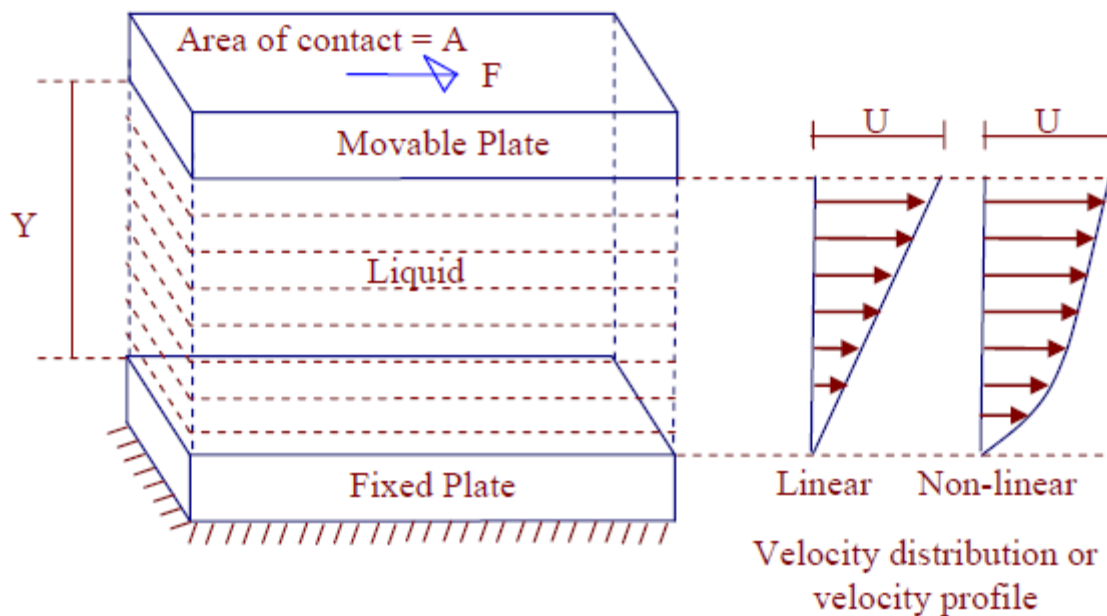

Figure 1.3.1 Definition diagram of Liquid viscosity

[Source: "[https://en.wikiversity.org/wiki/Fluid_Mechanics_for_Mechanical_Engineers/fluid Properties](https://en.wikiversity.org/wiki/Fluid_Mechanics_for_Mechanical_Engineers/fluid_Properties)"]

◆ $F \propto A$

◆ $F \propto \frac{1}{Y}$

◆ $F \propto U$

$$\therefore F \propto \frac{AU}{Y}$$

$$F = \mu \cdot \frac{AU}{Y}$$



' μ ' is the constant of proportionality called Dynamic Viscosity or Absolute Viscosity or Coefficient of Viscosity or Viscosity of the fluid.

$$\frac{F}{A} = \mu \cdot \frac{U}{Y} \longrightarrow \therefore \tau = \mu \frac{U}{Y}$$

' τ ' is the force required; Per Unit area called 'Shear Stress'. The above equation is called Newton's law of viscosity.

Velocity gradient or rate of shear strain:

It is the difference in velocity per unit distance between any two layers.

If the velocity profile is linear then velocity gradient is given by U/Y . If the velocity profile is non – linear then it is given by du/dy

Unit of force (F): N

- ◆ Unit of distance between the two plates (Y): m
- ◆ Unit of velocity (U): m/s
- ◆ Unit of velocity gradient : $\frac{U}{Y} = \frac{\text{m/s}}{\text{m}} = /s = \text{s}^{-1}$
- ◆ Unit of dynamic viscosity (τ): $\tau = \mu \frac{u}{y}$

$$\mu = \frac{\tau y}{U}$$

$$\Rightarrow \frac{\text{N/m}^2 \cdot \text{m}}{\text{m/s}}$$

$$\mu \Rightarrow \frac{\text{N} \cdot \text{sec}}{\text{m}^2} \text{ or } \mu \Rightarrow \text{Pa} \cdot \text{s}$$

NOTE: In CGS system unit of dynamic viscosity is $\frac{\text{dyne} \cdot \text{s}}{\text{cm}^2}$ and is called poise (P).

If the value of μ is given in poise, multiply it by 0.1 to get it in $\frac{\text{NS}}{\text{m}^2}$.

1 Centipoises = 10^{-2} Poise.

◆ Effect of Pressure on Viscosity of fluids:

Pressure has very little or no effect on the viscosity of fluids.

◆ Effect of Temperature on Viscosity of fluids:

❖ *Effect of temperature on viscosity of liquids:* Viscosity of liquids is due to cohesive force between the molecules of adjacent layers. As the temperature

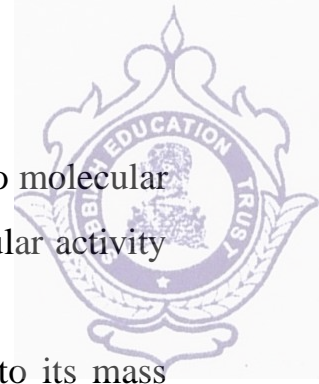

increases cohesive force decreases and hence viscosity decreases.

- ❖ *Effect of temperature on viscosity of gases:* Viscosity of gases is due to molecular activity between adjacent layers. As the temperature increases molecular activity increases and hence viscosity increases.

Kinematics Viscosity: It is the ratio of dynamic viscosity of the fluid to its mass density.

$$\therefore \text{Kinematic Viscosity} = \frac{\mu}{\rho}$$

Unit of Kinematics Viscosity

$$\text{KV} \Rightarrow \frac{\mu}{\rho}$$

$$\Rightarrow \frac{\text{NS} / \text{m}^2}{\text{kg} / \text{m}^3}$$

$$= \frac{\text{NS}}{\text{m}^2} \times \frac{\text{m}^3}{\text{kg}}$$

$$= \left(\frac{\text{kg m}}{\text{s}^2} \right) \times \frac{\text{s}}{\text{m}^2} \times \frac{\text{m}^3}{\text{kg}} = \text{m}^2 / \text{s}$$

$$F = ma$$

$$N = \text{Kg} \cdot \text{m} / \text{s}^2$$

\therefore Kinematic Viscosity = m^2 / s

NOTE: Unit of kinematics Viscosity in CGS system is cm^2/s and is called stoke (S)

If the value of KV is given in stoke, multiply it by 10^{-4} to convert it into m^2/s .



Problem 4: Viscosity of water is 0.01 poise. Find its kinematics viscosity if specific gravity is 0.998.

Kinematics viscosity = ?

$$S = 0.998$$

$$S = \frac{\rho}{\rho_{\text{standard}}}$$

$$\begin{aligned} \mu &= 0.01 \text{ P} \\ &= 0.01 \times 0.1 \end{aligned}$$

$$\mu = 0.001 \frac{\text{NS}}{\text{m}^2}$$

$$\therefore \text{Kinematic Viscosity} = \frac{\mu}{\rho}$$

$$0.998 = \frac{\rho}{1000}$$

$$= \frac{0.001}{998}$$

$$\text{KV} = 1 \times 10^{-6} \text{ m}^2/\text{s}$$

$$\rho = 998 \text{ kg/m}^3$$

Problem 5: A Plate at a distance 0.0254 mm from a fixed plate moves at 0.61 m/s and requires a force of 1.962 N/m² area of plate. Determine dynamic viscosity of liquid between the plates.



$$\tau = 1.962 \text{ N/m}^2$$

$$\mu = ?$$

Assuming linear velocity distribution

$$\tau = \mu \frac{U}{Y}$$

$$1.962 = \mu \times \frac{0.61}{0.0254 \times 10^{-3}}$$

$$\mu = 8.17 \times 10^{-5} \frac{\text{NS}}{\text{m}^2}$$

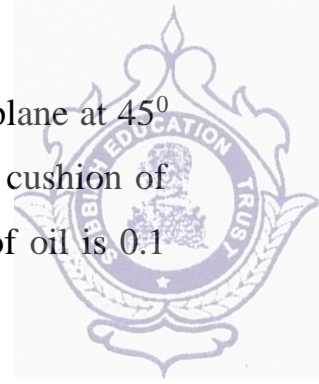

Problem 6 : A plate having an area of 1m^2 is dragged down an inclined plane at 45° to horizontal with a velocity of 0.5m/s due to its own weight. There is a cushion of liquid 1mm thick between the inclined plane and the plate. If viscosity of oil is $0.1\text{Pa}\cdot\text{s}$ find the weight of the plate.

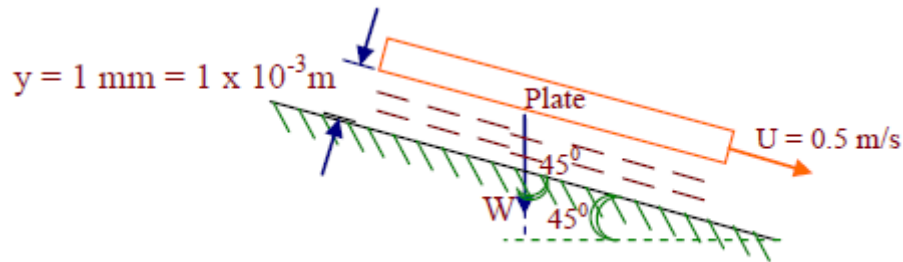

$$A = 1\text{m}^2$$

$$U = 0.5\text{m/s}$$

$$Y = 1 \times 10^{-3}\text{m}$$

$$\mu = 0.1\text{NS/m}^2$$

$$W = ?$$

$$F = W \times \cos 45^\circ$$

$$= W \times 0.707$$

$$F = 0.707W$$

$$\tau = \frac{F}{A}$$

$$\tau = \frac{0.707W}{1}$$

$$\tau = 0.707WN/\text{m}^2$$

Assuming linear velocity distribution,

$$\tau = \mu \cdot \frac{U}{Y}$$

$$0.707W = 0.1 \times \frac{0.5}{1 \times 10^{-3}}$$

$$W = 70.72\text{N}$$



Problem 7: A flat plate is sliding at a constant velocity of 5 m/s on a large horizontal table. A thin layer of oil (of absolute viscosity = 0.40 N-s/m²) separates the plate from the table. Calculate the thickness of the oil film (mm) to limit the shear stress in the oil layer to 1 kPa.

Given : $\tau = 1 \text{ kPa} = 1000 \text{ N/m}^2$; $U = 5 \text{ m/s}$; $\mu = 0.4 \text{ N-s/m}^2$

Applying Newton's Viscosity law for the oil film -

$$\tau = \mu \frac{du}{dy} = \mu \frac{U}{y}$$

$$1000 = 0.4 \frac{5}{y}$$

$$y = 2 \times 10^{-3} = 2 \text{ mm}$$

Problem 8: A shaft of ϕ 20mm and mass 15kg slides vertically in a sleeve with a velocity of 5 m/s. The gap between the shaft and the sleeve is 0.1mm and is filled with oil. Calculate the viscosity of oil if the length of the shaft is 500mm.

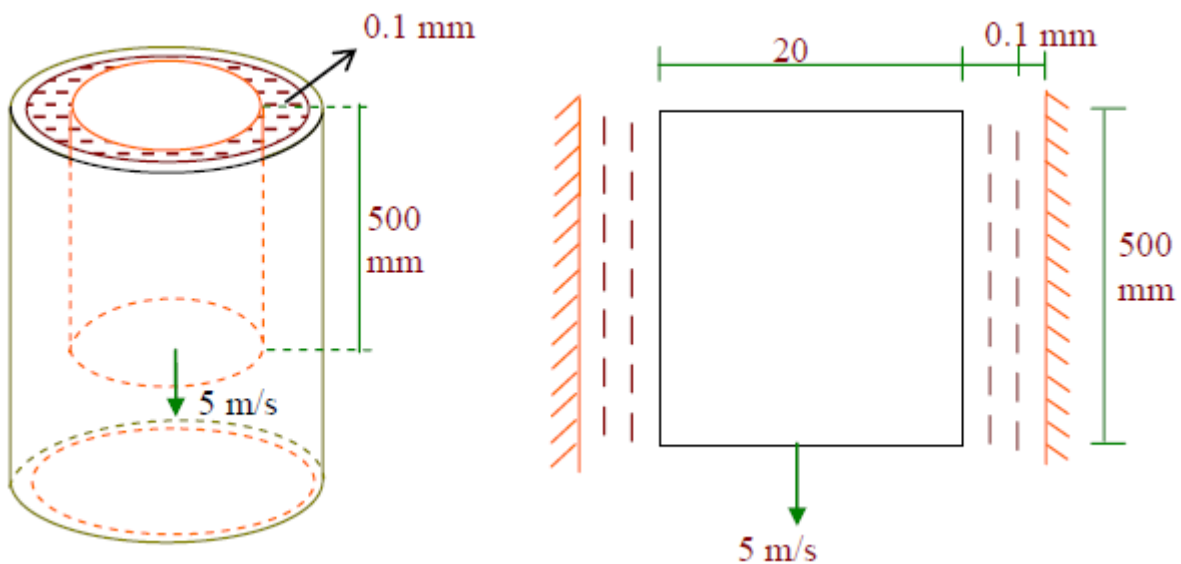



$$D = 20\text{mm} = 20 \times 10^{-3}\text{m}$$

$$M = 15\text{ kg}$$

$$W = 15 \times 9.81$$

$$W = 147.15\text{N}$$

$$y = 0.1\text{mm}$$

$$y = 0.1 \times 10^{-3}\text{mm}$$

$$U = 5\text{m/s}$$

$$F = W$$

$$F = 147.15\text{N}$$

$$\mu = ?$$

$$A = \pi D L$$

$$A = \pi \times 20 \times 10^{-3} \times 0.5$$

$$A = 0.031\text{ m}^2$$

$$\tau = \mu \cdot \frac{U}{Y}$$

$$4746.7 = \mu \times \frac{5}{0.1 \times 10^{-3}}$$

$$\mu = 0.095 \frac{\text{NS}}{\text{m}^2}$$

$$\tau = \frac{F}{A}$$

$$= \frac{147.15}{0.031}$$

$$\tau = 4746.7\text{N} / \text{m}^2$$

Problem 9 : If the equation of velocity profile over 2 plate is $V = 2y^{2/3}$ in which 'V' is the velocity in m/s and 'y' is the distance in 'm' . Determine shear stress at (i) $y = 0$ (ii) $y = 75\text{mm}$. Take $\mu = 8.35\text{P}$.

a. at $y = 0$

b. at $y = 75\text{mm}$

$$= 75 \times 10^{-3}\text{m}$$



$$\tau = 8.35 \text{ P}$$

$$= 8.35 \times 0.1 \frac{\text{NS}}{\text{m}^2}$$

$$= 0.835 \frac{\text{NS}}{\text{m}^2}$$

$$V = 2y^{2/3}$$

$$\frac{dv}{dy} = 2 \times \frac{2}{3} y^{2/3-1}$$

$$= \frac{4}{3} y^{-1/3}$$

$$\text{at, } y = 0, \frac{dv}{dy} = 3 \frac{4}{\sqrt[3]{0}} = \infty$$

$$\text{at, } y = 75 \times 10^{-3} \text{ m, } \frac{dv}{dy} = 3 \frac{4}{\sqrt[3]{75 \times 10^{-3}}}$$

$$\frac{dv}{dy} = 3.16 / \text{s}$$

$$\tau = \mu \cdot \frac{dv}{dy}$$

$$\text{at, } y = 0, \tau = 0.835 \times \infty$$

$$\tau = \infty$$

$$\text{at, } y = 75 \times 10^{-3} \text{ m, } \tau = 0.835 \times 3.16$$

$$\tau = 2.64 \text{ N/m}^2$$

Problem 10 : A circular disc of 0.3m dia and weight 50 N is kept on an inclined surface with a slope of 45° . The space between the disc and the surface is 2 mm and is filled with oil of dynamics viscosity 1N/Sm^2 . What force will be required to pull the disk up the inclined plane with a velocity of 0.5m/s.

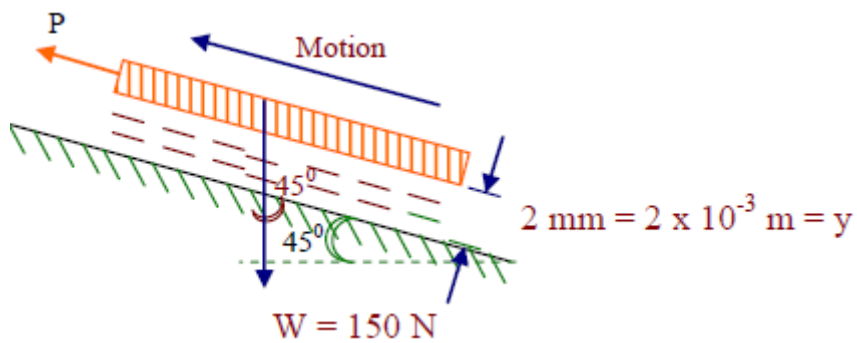

$$D = 0.3\text{m}$$

$$A = \frac{\pi \times 0.3\text{m}^2}{4}$$

$$A = 0.07\text{m}^2$$

$$W = 50\text{N}$$

$$\mu = 1 \frac{\text{NS}}{\text{m}^2}$$

$$F = P - 50 \cos 45$$

$$F = (P - 35.35)$$

$$\frac{y = 2 \times 10^{-3} \text{m}}{U = 0.5 \text{m/s}}$$

$$\nu = \frac{(P - 35.35)}{0.07} \text{N/m}^2$$

$$\tau = \mu \cdot \frac{U}{Y}$$

$$\left(\frac{P - 35.35}{0.07} \right) = 1 \times \frac{0.5}{2 \times 10^{-3}}$$

$$P = 52.85\text{N}$$

Problem 10 : Two large surfaces are 2.5 cm apart. This space is filled with glycerin of absolute viscosity 0.82 NS/m². Find what force is required to drag a plate of area 0.5m² between the two surfaces at a speed of 0.6m/s. (i) When the plate is equidistant from the surfaces, (ii) when the plate is at 1cm from one of the surfaces.

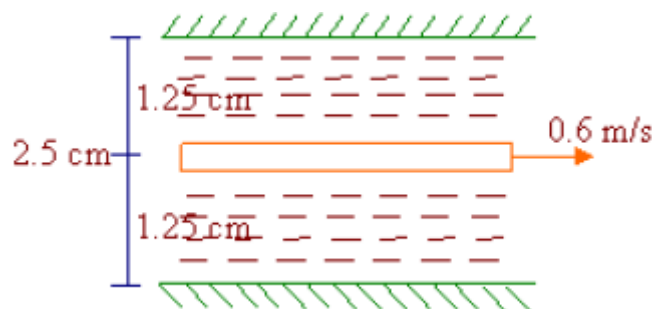



$$U = \frac{\pi DN}{60}$$

$$= \frac{\pi \times 0.4 \times 190}{60}$$

$$U = 3.979 \text{ m/s}$$

$$\tau = \mu \cdot \frac{U}{Y}$$

$$= 0.6 \times \frac{3.979}{1.5 \times 10^{-3}}$$

$$\tau = 1.592 \times 10^3 \text{ N/m}^2$$

$$\frac{F}{A} = 1.59 \times 10^3$$

$$F = 1.591 \times 10^3 \times 0.11$$

$$F = 175.01 \text{ N}$$

$$T = F \times R$$

$$= 175.01 \times 0.2$$

$$T = 35 \text{ Nm}$$

$$P = \frac{2\pi NT}{60,000}$$

$$P = 0.6964 \text{ KW}$$

$$P = 696.4 \text{ W}$$

Let F_1 be the force required to overcome viscosity resistance of liquid above the plate and F_2 be the force required to overcome viscous resistance of liquid below the plate. In this case $F_1 = F_2$. Since the liquid is same on either side or the plate is equidistant from the surfaces.

$$\tau_1 = \mu_1 \frac{U}{Y}$$

$$\tau_1 = 0.82 \times \frac{0.6}{0.0125}$$



$$\tau_1 = 39.36 \text{ N/m}^2$$

$$\frac{F_1}{A} = 39.36$$

$$F_1 = 19.68 \text{ N}$$

Total force required to drag the plate = $F_1 + F_2 = 19.68 + 19.68$

$$F = 39.36 \text{ N}$$

Case (ii) when the plate is at 1 cm from one of the surfaces

Here $F_1 \neq F_2$

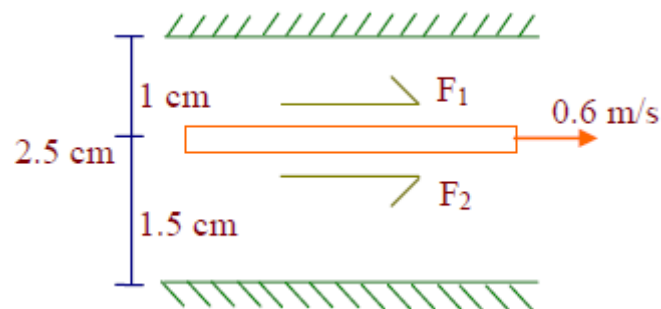

$$F/A = 49.2$$

$$F_1 = 49.2 \times 0.5$$

$$F_1 = 24.6 \text{ N}$$

$$F_2 / A = 32.8$$

$$F_2 = 32.8 \times 0.5$$

$$F_2 = 16.4 \text{ N}$$

$$\text{Total Force } F = F_1 + F_2 = 24.6 + 16.4$$

$$F = 41 \text{ N}$$

6. Capillarity :

Capillarity is the phenomena by which liquids will rise or fall in a tube of small diameter dipped in them. Capillarity is due to cohesion adhesion and surface tension of liquids. If adhesion is more than cohesion then there will be capillary rise. If cohesion is greater than adhesion then will be capillary fall or depression. The surface tensile force supports capillary rise or depression.

$$h = \frac{4\sigma \cos\theta}{\gamma D}$$

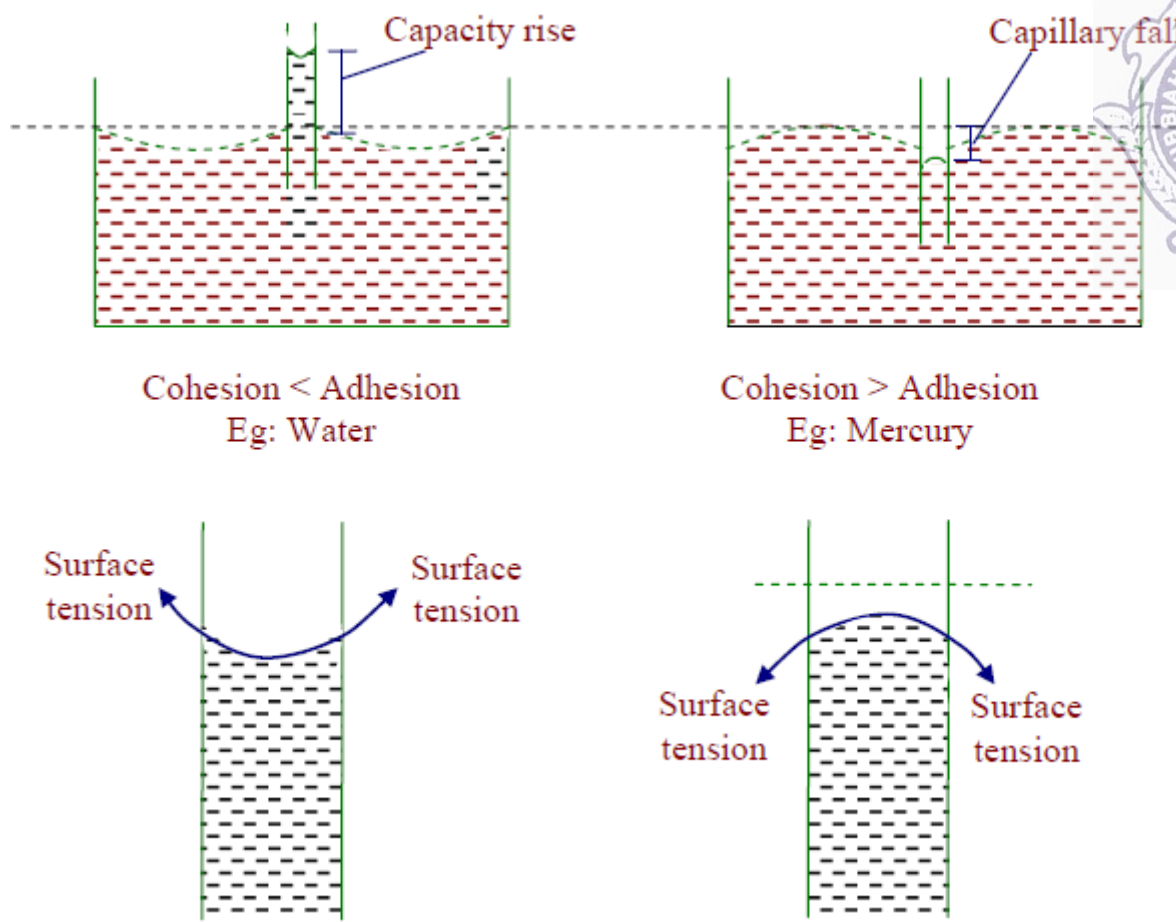
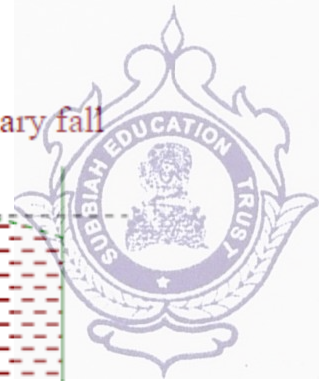

Figure 1.3.2 Capillarity

[Source: "https://en.wikiversity.org/wiki/Fluid_Mechanics_for_Mechanical_Engineers/fluid Properties"]

Problem 11 : Capillary tube having an inside diameter 5mm is dipped in water at 20⁰. Determine the height of water which will rise in tube. Take $\sigma=0.0736\text{N/m}$ at 20⁰ C.

$$h = \frac{4\sigma \cos\theta}{\gamma D}$$

$$= \frac{4 \times 0.0736 \times \cos\theta}{9810 \times 5 \times 10^{-3}}$$

$$h = 6 \times 10^{-3} \text{ m}$$

$$\theta = 0^{\circ} \text{ (assumed)}$$

$$\gamma = 9810 \text{ N/m}^3$$

Problem 12 : Calculate capillary rise in a glass tube when immersed in Hg at 20⁰C. Assume σ for Hg at 20⁰C as 0.51N/m. The diameter of the tube is 5mm. $\theta = 130^{\circ}$.

$$S = \frac{\gamma}{\gamma_{\text{standard}}}$$

$$h = \frac{4\sigma \cos\theta}{\gamma D}$$

$$13.6 = \frac{\gamma}{9810}$$

$$h = -1.965 \times 10^{-3} \text{ m}$$

$$\gamma = 133.416 \times 10^3 \text{ N/m}^3$$

-ve sign indicates capillary depression.

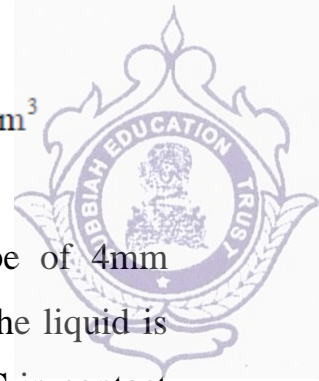

Problem 13: Calculate the capillary effect in millimeters a glass tube of 4mm diameter, when immersed in (a) water (b) mercury. The temperature of the liquid is 20°C and the values of the surface tension of water and mercury at 20°C in contact with air are 0.073575 and 0.51 N/m respectively. The angle of contact for water is zero that for mercury 130° . Take specific weight of water as 9790 N/m^3 .

Given:

$$\text{Diameter of tube} \Rightarrow d = 4 \text{ mm} = 4 \times 10^{-3} \text{ m}$$

$$\text{Capillary effect (rise or depression)} \Rightarrow h = \frac{4\sigma \cos \theta}{\rho \times g \times d}$$

σ = Surface tension in kg f/m

θ = Angle of contact and ρ = density

Capillary effect for water

$$\sigma = 0.073575 \text{ N/m}, \quad \theta = 0^\circ$$

$$\rho = 998 \text{ kg/m}^3 @ 20^\circ \text{C}$$

$$h = \frac{4 \times 0.073575 \times \cos 0^\circ}{998 \times 9.81 \times 4 \times 10^{-3}} = 7.51 \times 10^{-3} \text{ m}$$

$$= 7.51 \text{ mm.}$$

Capillary effect for mercury:

$$\sigma = 0.51 \text{ N/m}, \quad \theta = 130^\circ$$

$$\rho = \rho_{\text{Hg}} \times 1000 = 13.6 \times 1000 = 13600 \text{ kg/m}^3$$

$$= - 2.46 \text{ mm.}$$

-Ve indicates capillary depression.

7.Surface Tension:

Surface tension is defined as the tensile force acting on the surface of a liquid in contact with a gas or on the surface between two immiscible liquids such that the contact surface behaves like a membrane under tension

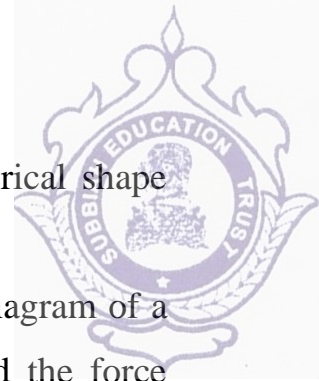

Excess Pressure inside a Water Droplet:

Pressure inside a Liquid droplet: Liquid droplets tend to assume a spherical shape since a sphere has the smallest surface area per unit volume.

The pressure inside a drop of fluid can be calculated using a free-body diagram of a spherical shape of radius R cut in half, as shown in Figure below and the force developed around the edge of the cut sphere is $2\pi R\sigma$. This force must be balance with the difference between the internal pressure p_i and the external pressure Δp acting on the circular area of the cut. Thus,

$$2\pi R\sigma = \Delta p \pi R^2$$

$$\Delta p = (P_{internal} - P_{external}) = \frac{2 \times \sigma}{R} = \frac{4 \times \sigma}{D}$$



Figure 1.3.3 Surface Tension inside a Water Droplet

[Source: "https://en.wikiversity.org/wiki/Fluid_Mechanics_for_Mechanical_Engineers/fluid Properties"]

The excess pressure within a Soap bubble:

The fact that air has to be blown into a drop of soap solution to make a bubble should suggest that the pressure within the bubble is greater than that outside. This is in fact the case: this excess pressure creates a force that is just balanced by the inward pull of the soap film of the bubble due to its surface tension.

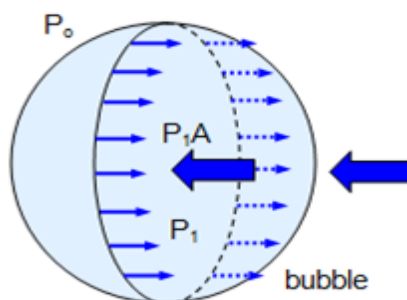
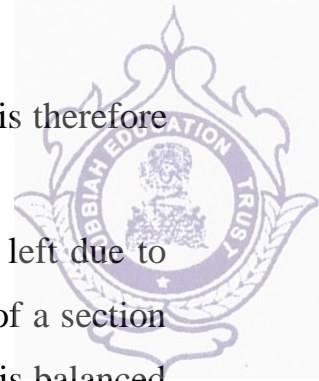

Figure 1.3.4 Surface Tension within a Soap bubble

[Source: "https://en.wikiversity.org/wiki/Fluid_Mechanics_for_Mechanical_Engineers/fluid Properties"]

Consider a soap bubble of radius r as shown in Figure 1. Let the external pressure be



P_0 and the internal pressure P_1 . The excess pressure ΔP within the bubble is therefore given by: Excess pressure $\Delta P = (P_1 - P_0)$

Consider the left-hand half of the bubble. The force acting from right to left due to the internal excess pressure can be shown to be PA , where A is the area of a section through the centre of the bubble. If the bubble is in equilibrium this force is balanced by a force due to surface tension acting from left to right. This force is $2 \times 2\pi r\sigma$ (the factor of 2 is necessary because the soap film has two sides) where ' σ ' is the coefficient of surface tension of the soap film. Therefore

$$2 \times 2\pi r\sigma = \Delta p A = \Delta p \pi r^2 \text{ giving:}$$

$$\text{Excess pressure in a soap bubble (P)} = 4\sigma/r$$

8. Compressibility:

Compressibility is the reciprocal of the bulk modulus of elasticity, K which is defined as the ratio of compressive stress to volumetric strain.

Bulk Modulus (K):

When a solid or fluid (liquid or gas) is subjected to a uniform pressure all over the surface, such that the shape remains the same, then there is a change in volume.

Then the ratio of normal stress to the volumetric strain within the elastic limits is called as Bulk modulus. This is denoted by K .

$$K = \frac{\text{Normal stress}}{\text{volumetric strain}}$$

$$K = \frac{F/A}{-\Delta V/V} = \frac{-pV}{\Delta V}$$

where p = increase in pressure; V = original volume; ΔV = change in volume

The negative sign shows that with increase in pressure p , the volume decreases by ΔV i.e. if p is positive, ΔV is negative. The reciprocal of bulk modulus is called compressibility.

$$C = \text{Compressibility} = \frac{1}{K} = \frac{\Delta V}{pV}$$

S.I. unit of compressibility is $N^{-1}m^2$ and C.G.S. unit is $\text{dyne}^{-1} \text{cm}^2$.

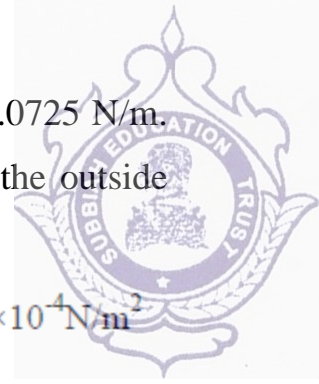

Problem 13: The surface tension of water in contact with air at 20°C is 0.0725 N/m. The pressure inside a droplet of water is to be 0.02 N/cm² greater than the outside pressure. Calculate the diameter of the droplet of water.

Given: Surface Tension of Water $\sigma = 0.0725$ N/m, $\Delta p = 0.02$ N/cm² = 0.02×10^{-4} N/m²

Let 'D' be the diameter of jet

$$\Delta p = \frac{4\sigma}{D}$$

$$0.02 \times 10^{-4} = \frac{4 \times 0.0725}{D}$$

$$D = 0.00145 \text{ m} = 1.45 \text{ mm}$$

Problem 14: Find the surface tension in a soap bubble of 40mm diameter when inside pressure is 2.5 N/m² above the atmosphere.

Given: $D = 40 \text{ mm} = 0.04$ m, $\Delta p = 2.5$ N/m²

Let ' σ ' be the surface tension of soap bubble

$$\Delta p = \frac{8\sigma}{D}$$

$$2.5 = \frac{4\sigma}{0.04}$$

$$\sigma = 0.0125 \text{ N/m}$$

9. Vapour Pressure

Vapour pressure is a measure of the tendency of a material to change into the gaseous or vapour state, and it increases with temperature. The temperature at which the vapour pressure at the surface of a liquid becomes equal to the pressure exerted by the surroundings is called the boiling point of the liquid.

Vapor pressure is important to fluid flows because, in general, pressure in a flow decreases as velocity increases. This can lead to *cavitation*, which is generally destructive and undesirable. In particular, at high speeds the local pressure of a liquid sometimes drops below the vapor pressure of the liquid. In such a case, *cavitation* occurs. In other words, a "cavity" or bubble of vapor appears because the liquid vaporizes or boils at the location where the pressure dips below the local vapor pressure.

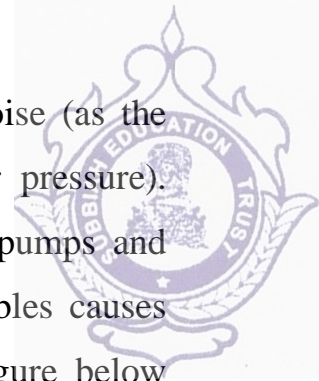

Cavitation is not desirable for several reasons. First, it causes noise (as the cavitation bubbles collapse when they migrate into regions of higher pressure). Second, it can lead to inefficiencies and reduction of heat transfer in pumps and turbines (turbo machines). Finally, the collapse of these cavitation bubbles causes pitting and corrosion of blades and other surfaces nearby. The left figure below shows a cavitating propeller in a water tunnel, and the right figure shows cavitation damage on a blade.

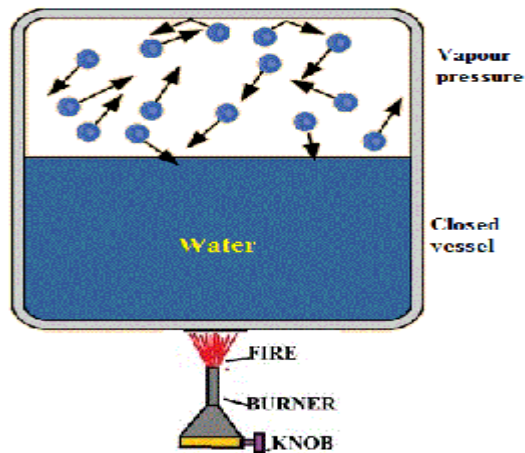
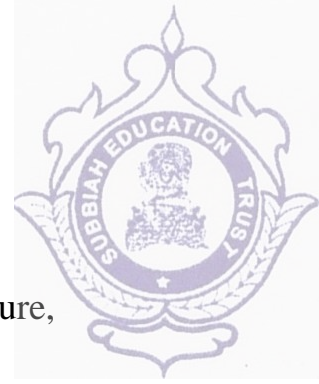

Figure 1.3.5 Vapour Pressure

[Source: "<https://www.hkdivedi.com/2017/12/vapour-pressure-and-cavitation.html>"]



1.4 PRESSURE MEASUREMENTS BY MANOMETERS

MANOMETER

A manometer is an instrument that uses a column of liquid to measure pressure, although the term is currently often used to mean any pressure instrument.

Two types of manometer, such as

1. Simple manometer
2. Differential manometer

The U type manometer, which is considered as a primary pressure standard, derives pressure utilizing the following equation:

$$P = P_2 - P_1 = h\omega \rho g$$

Where:

P = Differential pressure

P_1 = Pressure applied to the low pressure connection

P_2 = Pressure applied to the high pressure connection

$h\omega$ = is the height differential of the liquid columns between the two legs of the manometer

ρ = mass density of the fluid within the columns

g = acceleration of gravity

SIMPLE MANOMETER

A simple manometer consists of a glass tube having one of its ends connected to a point where pressure is to be measured and other end remains open to atmosphere. Common types of simple manometers are:

1. Piezometer
2. U tube manometer
3. Single Column manometer

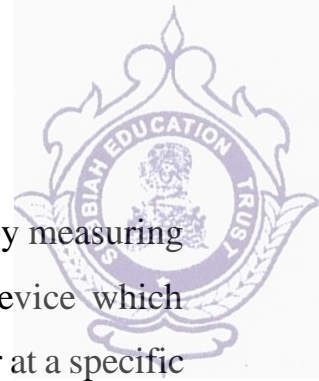

PIEZOMETER

A piezometer is either a device used to measure liquid pressure in a system by measuring the height to which a column of the liquid rises against gravity, or a device which measures the pressure (more precisely, the piezometric head) of groundwater at a specific point. A piezometer is designed to measure static pressures, and thus differs from a pitot tube by not being pointed into the fluid flow.

It is the simplest form of manometer used for measuring gauge pressures. One end of this manometer is connected to the point where pressure is to be measured and other end is open to the atmosphere as shown in Fig. The rise of liquid gives the pressure head at that point. If at a point A, the height of liquid say water is h in piezometer tube, then pressure at A

$$= \rho \times g \times h \frac{\text{N}}{\text{m}^2}.$$

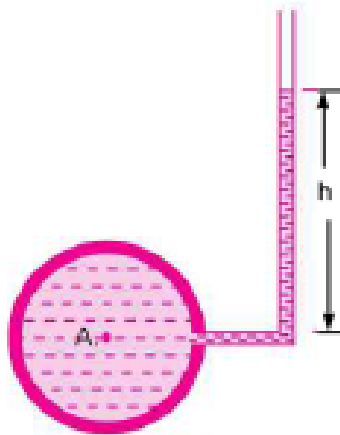

Figure 1.5.1 Piezometer

[Source: "Fluid Mechanics and Hydraulics Machines" by Dr.R.K.Bansal, Page: 43]

U TUBE MANOMETER

Manometers are devices in which columns of a suitable liquid are used to measure the difference in pressure between two points or between a certain point and the atmosphere.

Manometer is needed for measuring large gauge pressures. It is basically the modified form of the piezometric tube.

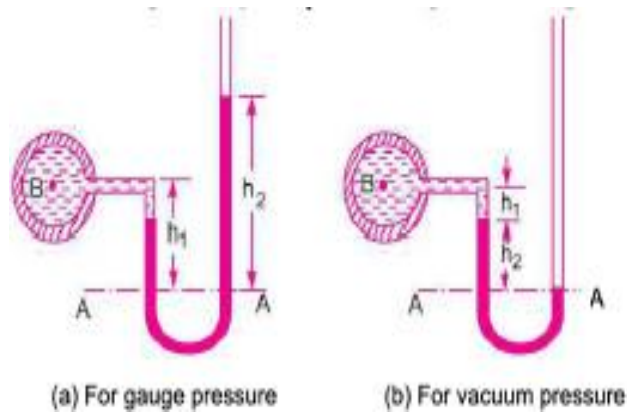

Figure 1.5.2 U Tube Manometer

[Source: "Fluid Mechanics and Hydraulics Machines" by Dr.R.K.Bansal, Page: 43]

(a) For Gauge Pressure. Let *B* is the point at which pressure is to be measured, whose value is *p*. The datum line is *A-A*.

- Let h_1 = Height of light liquid above the datum line
- h_2 = Height of heavy liquid above the datum line
- S_1 = Sp. gr. of light liquid
- ρ_1 = Density of light liquid = $1000 \times S_1$
- S_2 = Sp. gr. of heavy liquid
- ρ_2 = Density of heavy liquid = $1000 \times S_2$

As the pressure is the same for the horizontal surface. Hence pressure above the horizontal datum line *A-A* in the left column and in the right column of U-tube manometer should be same.

Pressure above *A-A* in the left column $= p + \rho_1 \times g \times h_1$

Pressure above *A-A* in the right column $= \rho_2 \times g \times h_2$

Hence equating the two pressures $p + \rho_1 g h_1 = \rho_2 g h_2$

$\therefore p = (\rho_2 g h_2 - \rho_1 \times g \times h_1).$

(b) For Vacuum Pressure. For measuring vacuum pressure, the level of the heavy liquid in the manometer will be as shown in Fig. 2.9 (b). Then

Pressure above *A-A* in the left column $= \rho_2 g h_2 + \rho_1 g h_1 + p$

Pressure head in the right column above *A-A* $= 0$

$\therefore \rho_2 g h_2 + \rho_1 g h_1 + p = 0$

$\therefore p = -(\rho_2 g h_2 + \rho_1 g h_1).$

Single Column Manometer

Single column manometer is a modified form of a U-tube manometer in which one side is a large reservoir and the other side is a small tube, open to the atmosphere.

There are two types of single column manometer:

1. Vertical single column manometer.
2. Inclined single column manometer.



1.Vertical single column Manometer

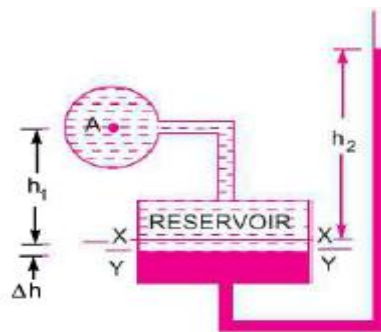

Figure 1.5.3 Vertical single column Manometer

[Source: "Fluid Mechanics and Hydraulics Machines" by Dr.R.K.Bansal, Page: 49]

Let Δh = Fall of heavy liquid in reservoir

h_2 = Rise of heavy liquid in right limb

h_1 = Height of centre of pipe above X-X

p_A = Pressure at A, which is to be measured

A = Cross-sectional area of the reservoir

a = Cross-sectional area of the right limb

S_1 = Sp. gr. of liquid in pipe

S_2 = Sp. gr. of heavy liquid in reservoir and right limb

ρ_1 = Density of liquid in pipe

ρ_2 = Density of liquid in reservoir

Fall of heavy liquid in reservoir will cause a rise of heavy liquid level in the right limb.

$$\therefore A \times \Delta h = a \times h_2$$

$$\therefore \Delta h = \frac{a \times h_2}{A}$$

...(i)

$$p_A = \frac{a \times h_2}{A} [\rho_2 g - \rho_1 g] + h_2 \rho_2 g - h_1 \rho_1 g$$

$A \gg a$

Then:
$$p_A = h_2 \rho_2 g - h_1 \rho_1 g$$



2. Inclined single column Manometer

This manometer is more sensitive. Due to the inclination the distance moved by the heavy liquid in the right limb will be more.

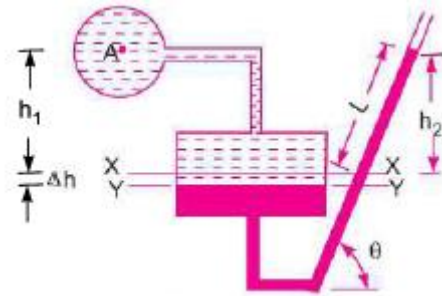

Figure 1.5.4 Inclined single column Manometer

[Source: "Fluid Mechanics and Hydraulics Machines" by Dr.R.K.Bansal, Page: 49]

Let L = Length of heavy liquid moved in right limb from X-X
 θ = Inclination of right limb with horizontal
 h_2 = Vertical rise of heavy liquid in right limb from X-X = $L \times \sin \theta$

From the eq.

$$p_A = h_2 \rho_2 g - h_1 \rho_1 g$$

By substituting the value of h_2 , We get:

$$p_A = \sin \theta \times \rho_2 g - h_1 \rho_1 g.$$

DIFFERENTIAL MANOMETER

Differential Manometers are devices used for measuring the difference of pressure between two points in a pipe or in two different pipes . A differential manometer consists of a U-tube, containing a heavy liquid, whose two ends are connected to the points, which difference of pressure is to be measure.

Most commonly types of differential manometers are:

- 1.U-tube differential manometer.
- 2.Inverted U-tube differential manometer



1.U-tube differential Manometer

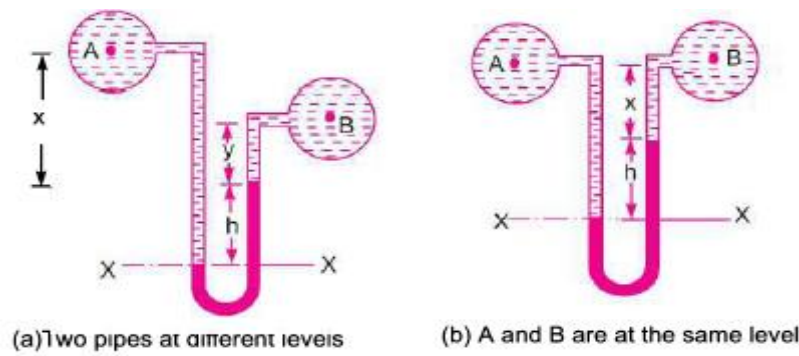

Figure 1.5.5 U-tube differential Manometer

[Source: “Fluid Mechanics and Hydraulics Machines” by Dr.R.K.Bansal, Page: 51]

In Fig. (a), the two points A and B are at different level and also contains liquids of different sp. gr. These points are connected to the U-tube differential manometer. Let the pressure at A and B are p_A and p_B .

- Let h = Difference of mercury level in the U-tube.
- y = Distance of the centre of B, from the mercury level in the right limb.
- x = Distance of the centre of A, from the mercury level in the right limb.
- ρ_1 = Density of liquid at A.
- ρ_2 = Density of liquid at B.
- ρ_g = Density of heavy liquid or mercury.

Taking datum line at X-X.

Pressure above X-X in the left limb = $\rho_1 g(h + x) + p_A$

where p_A = pressure at A.

Pressure above X-X in the right limb = $\rho_g \times g \times h + \rho_2 \times g \times y + p_B$

where p_B = Pressure at B.

Equating the two pressure, we have

$$\rho_1 g(h + x) + p_A = \rho_g \times g \times h + \rho_2 g y + p_B$$

$$\therefore p_A - p_B = \rho_g \times g \times h + \rho_2 g y - \rho_1 g(h + x)$$

$$= h \times g(\rho_g - \rho_1) + \rho_2 g y - \rho_1 g x$$

$$\therefore \text{Difference of pressure at A and B} = h \times g(\rho_g - \rho_1) + \rho_2 g y - \rho_1 g x$$

In Fig. (b), the two points A and B are at the same level and contains the same liquid of density ρ_1 . Then

Pressure above X-X in right limb = $\rho_g \times g \times h + \rho_1 \times g \times x + p_B$

Pressure above X-X in left limb = $\rho_1 \times g \times (h + x) + p_A$

Equating the two pressure

$$\rho_g \times g \times h + \rho_1 g x + p_B = \rho_1 \times g \times (h + x) + p_A$$

$$\therefore p_A - p_B = \rho_g \times g \times h + \rho_1 g x - \rho_1 g(h + x)$$

$$= g \times h(\rho_g - \rho_1).$$



2. Inverted U-tube differential Manometer

It consists of inverted U-tube, containing a light liquid. The two ends of the tube are connected to the points whose difference of pressure is to be measured. It is used for measuring differences of low pressures.

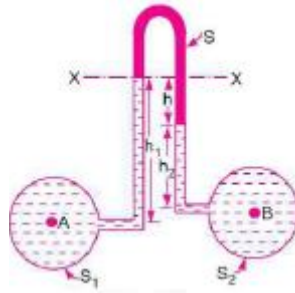

Figure 1.5.6 Inverted U-tube differential Manometer

[Source: "Fluid Mechanics and Hydraulics Machines" by Dr.R.K.Bansal, Page: 53]

Let the pressure at A is more than the pressure at B.

- Let
- h_1 = Height of liquid in left limb below the datum line
 - h_2 = Height of liquid in right limb
 - h = Difference of light liquid
 - ρ_1 = Density of liquid at A
 - ρ_2 = Density of liquid at B
 - ρ_s = Density of light liquid
 - p_A = Pressure at A
 - p_B = Pressure at B.

Taking X-X as datum line. Then pressure in the left limb below X-X
 $= p_A - \rho_1 \times g \times h_1.$

Pressure in the right limb below X-X
 $= p_B - \rho_2 \times g \times h_2 - \rho_s \times g \times h$

Equating the two pressure

$$p_A - \rho_1 \times g \times h_1 = p_B - \rho_2 \times g \times h_2 - \rho_s \times g \times h$$

or
$$p_A - p_B = \rho_1 \times g \times h_1 - \rho_2 \times g \times h_2 - \rho_s \times g \times h.$$

Problem 1: The right limb of a simple U – tube manometer containing mercury is open to the atmosphere, while the left limb is connected to a pipe in which a fluid of sp.gr.0.9 is flowing. The centre of pipe is 12cm below the level of mercury in the right limb. Find the pressure of fluid in the pipe, if the difference of mercury level in the two limbs is 20 cm.

Given, Sp.gr. of liquid S1= 0.9

Density of fluid $\rho_1 = S1 \times 1000 = 0.9 \times 1000$
 $= 900 \text{ kg/ m }^3$

Sp.gr. of mercury S2 = 13.6

Density of mercury $\rho_2 = 13.6 \times 1000 = 13600$
 kg/m^3

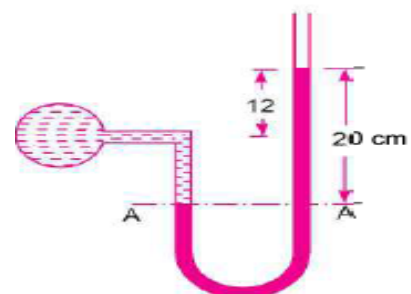



Difference of mercury level $h_2 = 20\text{cm} = 0.2\text{m}$

Height of the fluid from A – A $h_1 = 20 - 12 = 8\text{cm} = 0.08\text{ m}$

Let ‘P’ be the pressure of fluid in pipe

Equating pressure at A – A, we get $p + \rho_1gh_1 = \rho_2gh_2$

$$p + 900 \times 9.81 \times 0.08 = 13.6 \times 1000 \times 9.81 \times 0.2$$

$$p = 13.6 \times 1000 \times 9.81 \times 0.2 - 900 \times 9.81 \times 0.08$$

$$p = 26683 - 706$$

$$p = 25977 \text{ N/m}^2$$

$$p = 2.597 \text{ N/cm}^2$$

Pressure of fluid = 2.597 N/ cm²

Problem2: A simple U – tube manometer containing mercury is connected to a pipe in which a fluid of sp.gr. 0.8 And having vacuum pressure is flowing. The other end of the manometer is open to atmosphere. Find the vacuum pressure in pipe, if the difference of mercury level in the two limbs is 40cm. and the height of the fluid in the left tube from the centre of pipe is 15cm below.

Given,

$$\text{Sp.gr of fluid } S_1 = 0.8$$

$$\text{Sp.gr. of mercury } S_2 = 13.6$$

$$\text{Density of the fluid} = S_1 \times 1000 = 0.8 \times 1000 = 800$$

$$\text{Density of mercury} = 13.6 \times 1000$$

Difference of mercury level $h_2 = 40\text{cm} = 0.4\text{m}$

Height of the liquid in the left limb = $15\text{cm} = 0.15\text{m}$

Let the pressure in the pipe = p

Equating pressures above datum line A—A

$$\rho_2gh_2 + \rho_1gh_1 + P = 0$$

$$P = - [\rho_2gh_2 + \rho_1gh_1] = - [13.6 \times 1000 \times 9.81 \times 0.4 + 800 \times 9.81 \times 0.15]$$

$$= 53366.4 + 1177.2 = -54543.6 \text{ N/m}^2$$

$$\mathbf{P = - 5.454 \text{ N/cm}^2}$$

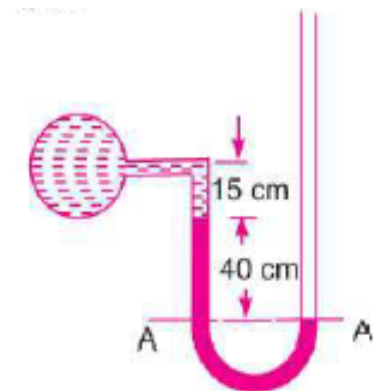

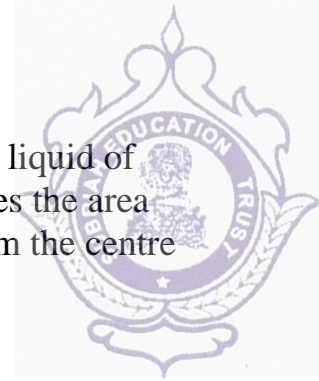

Problem 3: A single column manometer is connected to the pipe containing liquid of sp.gr.0.9. Find the pressure in the pipe if the area of the reservoir is 100 times the area of the tube of manometer. sp.gr. of mercury is 13.6. Height of the liquid from the centre of pipe is 20cm and difference in level of mercury is 40cm.

Given,

Sp.gr. of liquid in pipe $S_1 = 0.9$

Density $\rho_1 = 900 \text{ kg/ m}^3$

Sp.gr. of heavy liquid $S_2 = 13.6$

Density $\rho_2 = 13600$

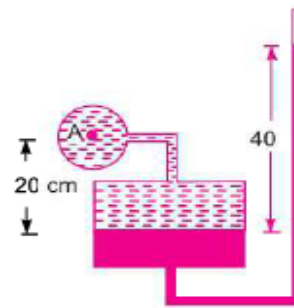

$$\frac{\text{Area of reservoir}}{\text{Area of right limb}} = \frac{A}{a} = 100$$

Height of the liquid $h_1 = 20\text{cm} = 0.2\text{m}$

Rise of mercury in the right limb $h_2 = 40\text{cm} = 0.4\text{m}$

$$p_A = \frac{a}{A} h_2[\rho_2 g - \rho_1 g] + h_2 \rho_2 g - h_1 \rho_1 g$$

$$\begin{aligned} &= \frac{1}{100} \times 0.4[13.6 \times 1000 \times 9.81 - 900 \times 9.81] + 0.4 \times 13.6 \times 1000 \times 9.81 - 0.2 \times 900 \times 9.81 \\ &= \frac{0.4}{100} [133416 - 8829] + 53366.4 - 1765.8 \\ &= 533.664 + 53366.4 - 1765.8 \text{ N/m}^2 = 52134 \text{ N/m}^2 = \mathbf{5.21 \text{ N/cm}^2}. \text{ Ans.} \end{aligned}$$

Pressure in pipe A = 5.21 N/ cm²

Problem 4: A pipe contains an oil of sp.gr.0.9. A differential manometer is connected at the two points A and B shows a difference in mercury level at 15cm. find the difference of pressure at the two points.

Given:

Sp.gr. of oil $S_1 = 0.9$: density $\rho_1 = 0.9 \times 1000 = 900 \text{ kg/ m}^3$

Difference of level in the mercury $h = 15\text{cm} = 0.15 \text{ m}$

Sp.gr. of mercury = 13.6, Density = $13.6 \times 1000 = 13600 \text{ kg/m}^3$

The difference of pressure $p_A - p_B = g \times h \times (\rho_2 - \rho_1)$

$$= 9.81 \times 0.15 (13600 - 900)$$

$$\mathbf{p_A - p_B = 18688 \text{ N/ m}^2}$$



Problem 5: A differential manometer is connected at two points A and B .At B air pressure is 9.81 N/cm² . Find absolute pressure at A.

Given:

Density of air = $0.9 \times 1000 = 900 \text{ kg/m}^3$

Density of mercury = $13.6 \times 10^3 \text{ kg/ m}^3$.

Let pressure at A is p_A

Taking datum as X – X

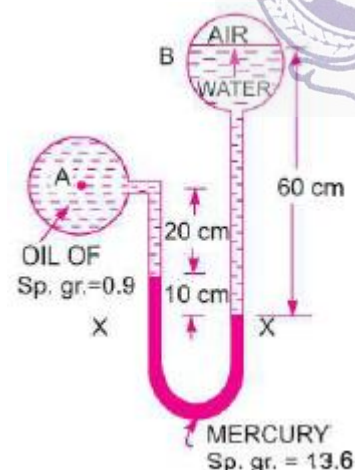

Pressure above X – X in the right limb

$$= 1000 \times 9.81 \times 0.6 + p_B = 5886 + 98100 = 103986$$

Pressure above X – X in the left limb

$$= 13.6 \times 10^3 \times 9.81 \times 0.1 + 900 \times 9.81 \times 0.2 + p_A$$

$$= 13341.6 + 1765.8 + p_A$$

Equating the two pressures heads

$$103986 = 13341.6 + 1765.8 + p_A$$

$$= 15107.4 + p_A$$

$$p_A = 103986 - 15107.4$$

$$= 88878.6 \text{ N/m}^2$$

$$p_A = \mathbf{8.887 \text{ N/cm}^2}$$

Problem 6: Water is flowing through two different pipes to which an inverted differential manometer having an oil of sp.gr. 0.8 is connected. The pressure head in the pipe A is 2m of water. Find the pressure in the pipe B for the manometer readings shown in fig.

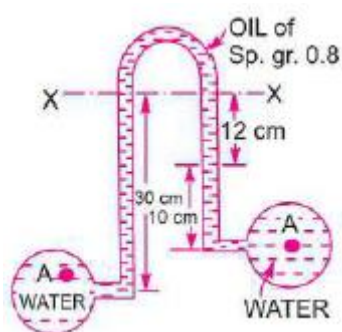



Given:

Pressure head at $A = \frac{p_A}{\rho g} = 2 \text{ m of water}$

$\therefore p_A = \rho \times g \times 2 = 1000 \times 9.81 \times 2 = 19620 \text{ N/m}^2$

Pressure below X – X in the left limb

$$= p_A - \rho_1 g h_1$$

$$= 19620 - 1000 \times 9.81 \times 0.3$$

$$= 16677 \text{ N/m}^2$$

Pressure below X – X in the right limb

$$= p_B - 1000 \times 9.81 \times 0.1 - 800 \times 9.81 \times 0.12$$

$$= p_B - 981 - 941.76 = p_B - 1922.76$$

Equating the two pressures, we get,

$$16677 = p_B - 1922.76$$

$$p_B = 16677 + 1922.76$$

$$\mathbf{p_B = 18599.76 \text{ N/m}^2}$$

Problem 7: A differential manometer is connected at two points A and B of two pipes. The pipe A contains liquid of sp.gr. = 1.5 while pipe B contains liquid of sp.gr. = 0.9. The pressures at A and B are 1 kgf/cm^2 and 1.80 Kg f/cm^2 respectively. Find the difference in mercury level in the differential manometer.

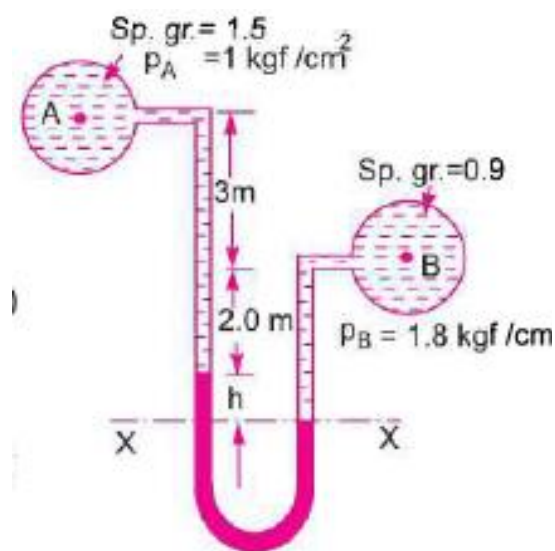



Sp.gr. of liquid at A $S_1 = 1.5$

Sp.gr. of liquid at B $S_2 = 0.9$

Pressure at A $p_A = 1 \text{ kgf/cm}^2 = 1 \times 10^4 \times \text{kg/m}^2 = 1 \times 10^4 \times 9.81 \text{ N/m}^2$

Pressure at B $p_B = 1.8 \text{ kgf/cm}^2 = 1.8 \times 10^4 \times 9.81 \text{ N/m}^2$ [1kgf = 9.81 N]

Density of mercury = $13.6 \times 1000 \text{ kg/m}^3$

Taking X – X as datum line

Pressure above X – X in left limb

$$= 13.6 \times 1000 \times 9.81 \times h + 1500 \times 9.81(2+3) + (9.81 \times 10^4)$$

Pressure above X – X in the right limb = $900 \times 9.81(h + 2) + 1.8 \times 9.81 \times 10^4$

Equating the two pressures, we get

$$13.6 \times 1000 \times 9.81h + 1500 \times 9.81 \times 5 + 9.81 \times 10^4 = 900 \times 9.81(h + 2) + 1.8 \times 9.81 \times 10^4$$

Dividing both sides by 1000×9.81

$$13.6 h + 7.5 + 10 = 0.9(h+2) + 18$$

$$(13.6 - 0.9) h = 1.8 + 18 - 17.5 = 19.8 - 17.5 = 2.3$$

$$h = 2.3 / 12.7 = 0.181 \text{ m}$$

$$\mathbf{h = 18.1 \text{ cm}}$$



1.5 BUOYANCY AND FLOATATION

Buoyancy or buoyancy force

When a body is immersed in fluid, an upward force is exerted by the fluid on the body. This force will be equal to the weight of the fluid displaced by the body and this force will be termed as force of buoyancy or buoyancy.

Let us consider we have one container filled with water as displayed here in following figure. We have one object of weight 7 N. Let us think that we are now immersing the object in to the liquid i.e. water.

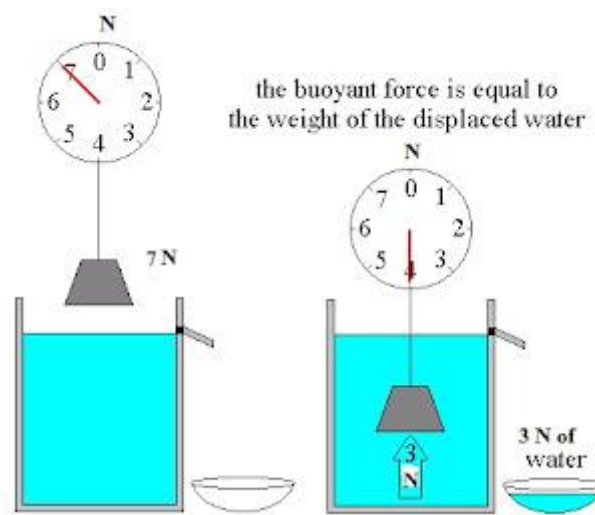

Once object will be immersed in the water, some amount of water will be displaced by the object and one upward force will be applied over the object by the water.

Weight of the displaced water will be equal to this upward force which will be exerted by the water on the object. As we can see from above figure that, water of weight 3N is displaced here and one upward force of 3N is exerted by the water over the object.

Conclusion for buoyancy force

Buoyancy force is the force which will be exerted on the object by the surrounding fluid. When one object will be immersed in the water, object will push the water and water will push back the object with as much force as it can.

$$\text{Force of buoyancy} = \text{Weight of the displaced fluid}$$

$$\text{Force of buoyancy} = \text{Weight of the object in air} - \text{Weight of the object in given water}$$

Positive buoyancy

Force of buoyancy will be greater than the weight of the object. Hence, object will float and this case will be termed as positive buoyancy.



Neutral buoyancy

Force of buoyancy will be equal to the weight of the object. Hence, object will be suspended in the fluid and this case will be termed as neutral buoyancy.

Negative buoyancy

Force of buoyancy will be less than the weight of the object. Hence, object will be sunk and this case will be termed as negative buoyancy.

Centre of buoyancy

As we know that when a body is immersed in fluid, an upward force is exerted by the fluid on the body. This force will be equal to the weight of the fluid displaced by the body and this force will be termed as force of buoyancy or buoyancy.

Buoyancy force will act through the centre of gravity of the displaced fluid and that point i.e. centre of gravity of the displaced fluid will be termed as centre of buoyancy.

Therefore we can define the term centre of buoyancy as the point through which the force of buoyancy is supposed to act.

Centre of buoyancy = Centre of gravity of the displaced fluid = Centre of gravity of the portion of the body immersed in the liquid

Let us explain the term centre of buoyancy

Let us consider one vessel as displayed here in following figure. Weight of vessel will be distributed throughout the length of vessel and will act downward over the entire structure of vessel.

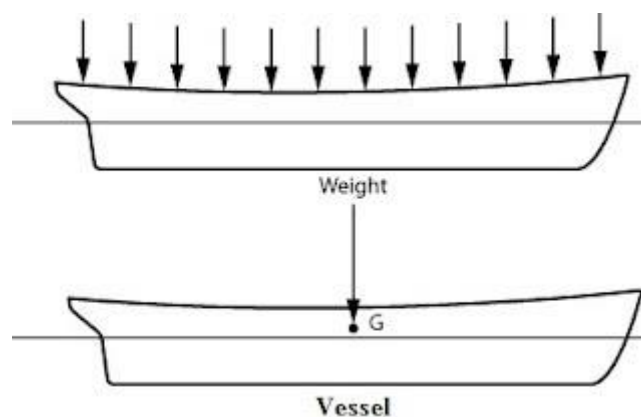

But, what do we consider?

We consider that complete weight of the vessel will act downward vertically through one point and that point will be termed as the centre of gravity of that vessel.

In similar way, buoyancy force will be supposed to act vertically in upward direction through a single point and that point will be termed as centre of buoyancy.

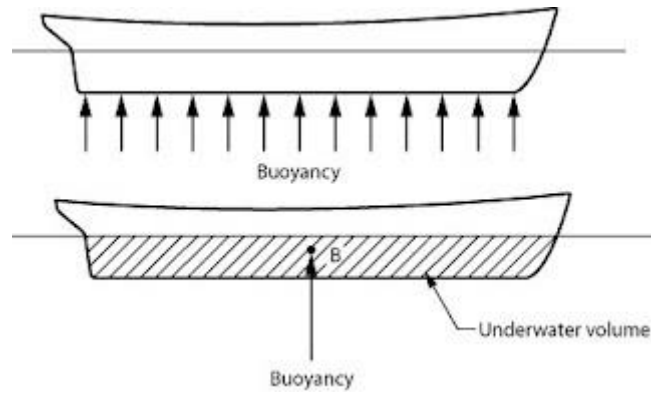

Meta-centre

Meta-centre is basically defined as the point about which a body in stable equilibrium will start to oscillate when body will be displaced by an angular displacement.

We can also define the meta-centre as the point of intersection of the axis of body passing through the centre of gravity and original centre of buoyancy and a vertical line passing through the centre of buoyancy of the body in tilted position.

Let us consider a body which is floating in the liquid. Let us assume that body is in equilibrium condition. Let us think that G is the centre of gravity of the body and B is the centre of buoyancy of the body when body is in equilibrium condition.

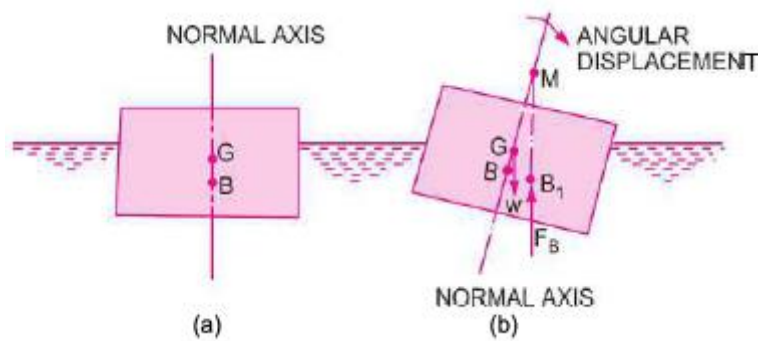

Figure 1.7.1 Meta-centre

[Source: “Fluid Mechanics and Hydraulics Machines” by Dr.R.K.Bansal, Page: 136]

In equilibrium situation, centre of gravity G and centre of buoyancy B will lie on same axis which is displayed here in above figure with a vertical line.

Let us assume that we have given an angular displacement to the body in clockwise direction as displayed here in above figure.

Centre of buoyancy will be shifted now towards right side from neutral axis and let us assume that it is now B_1 .

Line of action of buoyancy force passing through this new position will intersect the normal axis passing through the centre of gravity and centre of buoyancy in original



position of the body at a point M as displayed here in above figure. Where, M is the meta-centre.

Meta-centric height

Meta-centric height is basically defined as the distance between the meta-centre of the floating body and the centre of gravity of the body.

Therefore, MG in above figure will be termed as meta-centric height.



2.1 FLUID KINEMATICS

Kinematics is defined as a branch of science which deals with motion of particles without considering the forces causing the motion. The velocity at any point in a flow field at any time is studied in this. Once the velocity is known, then the pressure distribution and hence the forces acting on the fluid can be determined.

Stream line: A stream line is an imaginary line drawn in a flow field such that the tangent drawn at any point on this line represents the direction of velocity vector. From the definition it is clear that there can be no flow across stream line. Considering a particle moving along a stream line for a very short distance 'ds' having its components dx, dy and dz, along three mutually perpendicular co-ordinate axes. Let the components of velocity vector V_s along x, y and z directions be u, v and w respectively. The time taken by the fluid particle to move a distance 'ds' along the stream line with a velocity V_s is:

$$= \frac{ds}{V_s} \quad \text{Which is same as } t = \frac{dx}{u} = \frac{dy}{v} = \frac{dz}{w}$$

Hence the differential equation of the stream line may be written as:

$$\frac{dx}{u} = \frac{dy}{v} = \frac{dz}{w}$$

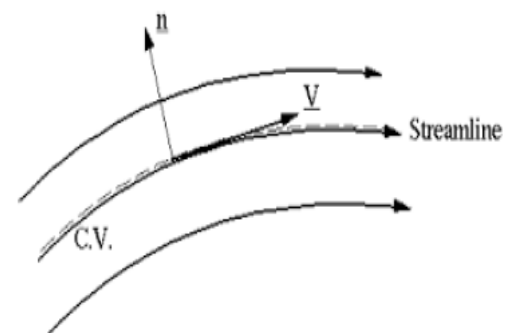

Path line: A path line is locus of a fluid particle as it moves along. In other words a path line is a curve traced by a single fluid particle during its motion. A stream line at time t_1 indicating the velocity vectors for particles A and B. At times t_2 and t_3 the particle A occupies the successive positions. The line containing these various positions of A represents its **Path line**

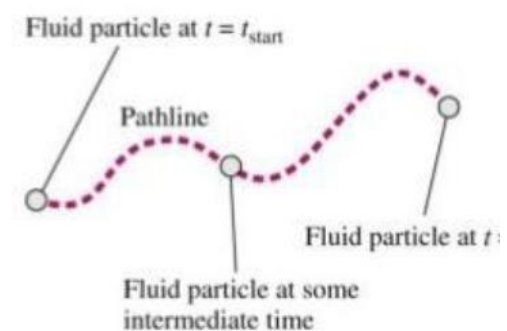

Streak line: When a dye is injected in a liquid or smoke subsequent motion of fluid particles passing a fixed point, the path followed by dye or smoke is called the **streak line**. Thus the streak line connects all particles passing through a given point.

In steady flow, the stream line remains fixed with respect to co-ordinate axes. Stream lines in steady flow also represent the path lines and streak lines. In unsteady flow, a fluid particle will not, in general, remain on the same stream line (except for unsteady uniform flow). Hence the stream lines and path lines do not coincide in unsteady non-uniform flow.

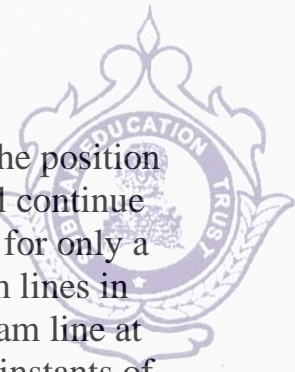

Instantaneous stream line: in a fluid motion which is independent of time, the position of stream line is fixed in space and a fluid particle following a stream line will continue to do so. In case of time dependent flow, a fluid particle follows a stream line for only a short interval of time, before changing over to another stream line. The stream lines in such cases are not fixed in space, but change with time. The position of a stream line at a given instant of time is known as **Instantaneous stream line**. For different instants of time, we shall have different Instantaneous stream lines in the same space. The Stream line, Path line and the streak line are one and the same, if the flow is steady.

Stream tube: If stream lines are drawn through a closed curve, they form a boundary surface across which fluid cannot penetrate. Such a surface bounded by stream lines is known as **Stream tube**.

From the definition of stream tube, it is evident that no fluid can cross the bounding surface of the stream tube. This implies that the quantity of fluid entering the stream tube at one end must be the same as the quantity leaving at the other end. The Stream tube is assumed to be a small cross-sectional area, so that the velocity over it could be considered uniform.

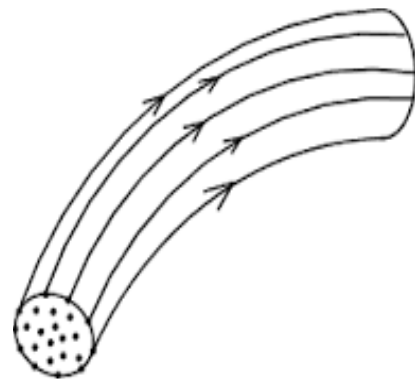



2.2 CLASSIFICATION AND TYPES OF FLOW

The fluid flow is classified as:

- i) Steady and unsteady flows.
- ii) Uniform and Non-uniform flows.
- iii) Laminar and Turbulent flows.
- iv) Compressible and incompressible flows.
- v) Rotational and Ir-rotational flows.
- vi) One, Two and Three dimensional flows.

i) Steady and Un-steady flows: Steady flow is defined as the flow in which the fluid characteristics like velocity, pressure, density etc. at a point do not change with time.

$$\frac{\partial V}{\partial t_{x,y,z}} = 0, \quad \frac{\partial p}{\partial t_{x,y,z}} = 0, \quad \frac{\partial \rho}{\partial t_{x,y,z}} = 0$$

Un-Steady flow is the flow in which the velocity, pressure, density at a point changes with respect to time. Thus for un-steady flow, we have

$$\frac{\partial V}{\partial t_{x,y,z}} \neq 0, \quad \frac{\partial p}{\partial t_{x,y,z}} \neq 0, \quad \frac{\partial \rho}{\partial t_{x,y,z}} \neq 0$$

ii) Uniform and Non-uniform flows: Uniform flow is defined as the flow in which the velocity at any given time does not change with respect to space. (i.e. the length of direction of flow)

For uniform flow

$$\frac{\partial V}{\partial s_{t=\text{const}}} = 0$$

Where ∂V = Change of velocity

∂s = Length of flow in the direction of – S

Non-uniform is the flow in which the velocity at any given time changes with respect to space.

For Non-uniform flow

$$\frac{\partial V}{\partial s_{t=\text{const}}} \neq 0$$

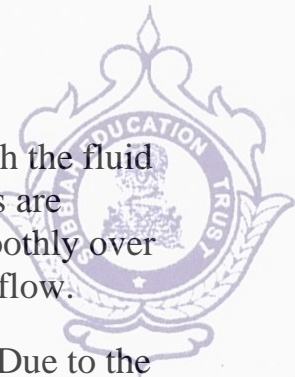

iii) Laminar and turbulent flow: Laminar flow is defined as the flow in which the fluid particles move along well-defined paths or stream line and all the stream lines are straight and parallel. Thus the particles move in laminas or layers gliding smoothly over the adjacent layer. This type of flow is also called streamline flow or viscous flow.

Turbulent flow is the flow in which the fluid particles move in a zigzag way. Due to the movement of fluid particles in a zigzag way, the eddies formation takes place, which are responsible for high energy loss. For a pipe flow, the type of flow is determined by a non- Dimensional number (VD/v) called the Reynolds number.

Where D = Diameter of pipe.

V = Mean velocity of flow in pipe.

v = Kinematic viscosity of fluid.

If the Reynolds number is less than 2000, the flow is called Laminar flow.

If the Reynolds number is more than 4000, it is called Turbulent flow.

If the Reynolds number is between 2000 and 4000 the flow may be Laminar or Turbulent flow.

iv) Compressible and Incompressible flows: Compressible flow is the flow in which the density of fluid changes from point to point or in other words the density is not constant for the fluid.

For compressible flow $\rho \neq \text{Constant}$.

In compressible flow is the flow in which the density is constant for the fluid flow. Liquids are generally incompressible, while the gases are compressible.

For incompressible flow $\rho = \text{Constant}$.

v) Rotational and Irrotational flows: Rotational flow is a type of flow in which the fluid particles while flowing along stream lines also rotate about their own axis. And if the fluid particles, while flowing along stream lines, do not rotate about their own axis, the flow is called Ir-rotational flow.

vi) One, Two and Three – dimensional flows:

One dimensional flow is a type of flow in which flow parameter such as velocity is a function of time and one space co-ordinate only, say 'x'. For a steady one- dimensional flow, the velocity is a function of one space co-ordinate only. The variation of velocities in other two mutually perpendicular directions is assumed negligible.

Hence for one dimensional flow $\mathbf{u} = \mathbf{f(x)}$, $\mathbf{v} = \mathbf{0}$ and $\mathbf{w} = \mathbf{0}$

Where u , v and w are velocity components in x , y and z directions respectively.

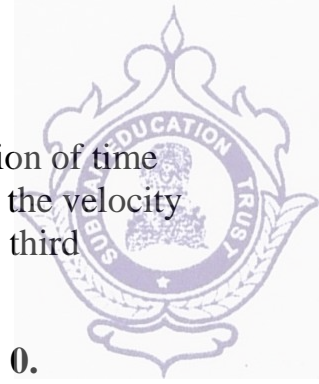

Two – dimensional flow is the type of flow in which the velocity is a function of time and two space co-ordinates, say x and y . For a steady two-dimensional flow the velocity is a function of two space co-ordinates only. The variation of velocity in the third direction is negligible.

Thus for two dimensional flow $\mathbf{u} = f_1(x, y)$, $\mathbf{v} = f_2(x, y)$ and $\mathbf{w} = 0$.

Three – dimensional flow is the type of flow in which the velocity is a function of time and three mutually perpendicular directions. But for a steady three-dimensional flow, the fluid parameters are functions of three space co-ordinates (x , y , and z) only.

Thus for **three- dimensional flow** $\mathbf{u} = f_1(x, y, z)$, $\mathbf{v} = f_2(x, y, z)$, $\mathbf{z} = f_3(x, y, z)$.

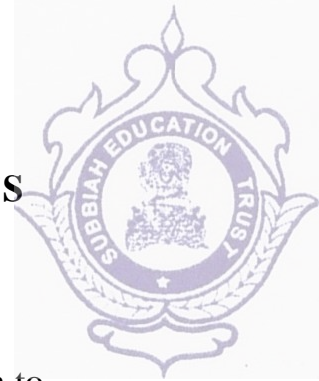

2.3 EULER'S EQUATION ALONG A STREAMLINE - BERNOULLI'S EQUATION – APPLICATIONS

EULER'S EQUATION OF MOTION

In this equation of motion the forces due to gravity and pressure are taken in to consideration. This is derived by considering the motion of the fluid element along a stream- line as:

Consider a stream-line in which flow is taking place in s- direction. Consider a cylindrical element of cross-section dA and length ds .

The forces acting on the cylindrical element are:

1. Pressure force $p dA$ in the direction of flow.
2. Pressure force $\left(p + \frac{\partial p}{\partial s} ds\right) dA$ opposite to the direction of flow
3. Weight of element $\rho g dA.ds$

Let θ is the angle between the direction of flow and the line of action of the weight of the element.

The resultant force on the fluid element in the direction of S must be equal to the mass of fluid element \times acceleration in the direction of s.

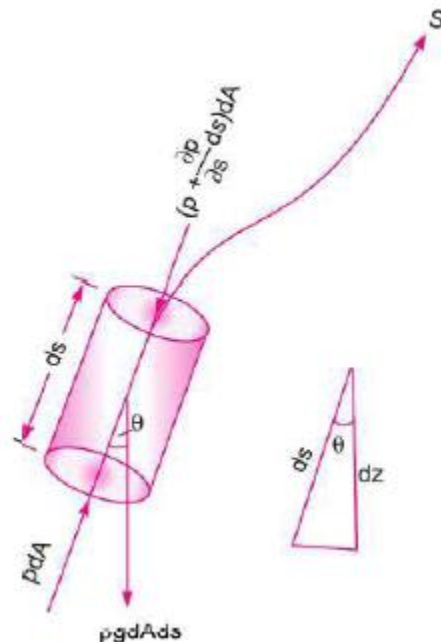

$$\begin{aligned} \therefore \quad p dA - \left(p + \frac{\partial p}{\partial s} ds\right) dA - \rho g dA ds \cos \theta \\ = \rho dA ds \times a_s \quad \text{-----(1)} \end{aligned}$$

Whereas is the acceleration in the direction of s.

Now $a_s = \frac{dv}{dt}$, where v is a function of s and t .

$$= \frac{\partial v}{\partial s} \frac{ds}{dt} + \frac{\partial v}{\partial t} = \frac{v \partial v}{\partial s} + \frac{\partial v}{\partial t} \left\{ \because \frac{ds}{dt} = v \right\}$$

If the flow is steady, $\frac{\partial v}{\partial t} = 0$

$$\therefore \quad a_s = \frac{v \partial v}{\partial s}$$

Substituting the value of a_s in equation (1) and simplifying, we get



$$-\frac{\partial p}{\partial s} ds dA - \rho g dA ds \cos \theta = \rho dA ds \times \frac{\partial v}{\partial s}$$

$$\text{Dividing by } \rho ds dA, -\frac{\partial p}{\rho \partial s} - g \cos \theta = \frac{v \partial v}{\partial s}$$

$$\text{or } \frac{\partial p}{\rho \partial s} + g \cos \theta + v \frac{\partial v}{\partial s} = 0$$

$$\text{But from Fig., we have } \cos \theta = \frac{dz}{ds}$$

$$\therefore \frac{1}{\rho} \frac{dp}{ds} + g \frac{dz}{ds} + \frac{v dv}{ds} = 0 \quad \text{or} \quad \frac{dp}{\rho} + g dz + v dv = 0$$

$$\text{or } \frac{dp}{\rho} + g dz + v dv = 0$$

\therefore This equation is known as **Euler's equation of motion**.

BERNOULLI'S EQUATION FROM EULER'S EQUATION

Bernoulli's equation is obtained by integrating the Euler's equation of motion as

$$\int \frac{dp}{\rho} + \int g dz + \int v dv = \text{constant}$$

$$\therefore \frac{p}{\rho} + gz + \frac{v^2}{2} = \text{constant}$$

$$\text{or } \frac{p}{\rho g} + z + \frac{v^2}{2g} = \text{constant}$$

$$\text{or } \frac{p}{\rho g} + \frac{v^2}{2g} + z = \text{constant}$$

The above equation is Bernoulli's equation in which

$\frac{p}{\rho g}$ = Pressure energy per unit weight of fluid or pressure head.

$\frac{v^2}{2g}$ = Kinetic energy per unit weight of fluid or Kinetic head.

z = Potential energy per unit weight of fluid or Potential head.

The following are the assumptions made in the derivation of Bernoulli's equation.

- i. The fluid is ideal. i.e. Viscosity is zero.
- ii. The flow is steady.



iii. The flow is incompressible.

iv. The flow is irrotational.

PROBLEM 1. Water is flowing through a pipe of 5cm dia. Under a pressure of 29.43N/cm² and with mean velocity of 2 m/sec. find the total head or total energy per unit weight of water at a cross-section, which is 5m above datum line.

Given: dia. Of pipe = 5cm = 0.05m
 Pressure P = 29.43N/cm² = 29.43 x 10⁴N/m²
 Velocity V = 2 m/sec
 Datum head Z = 5m

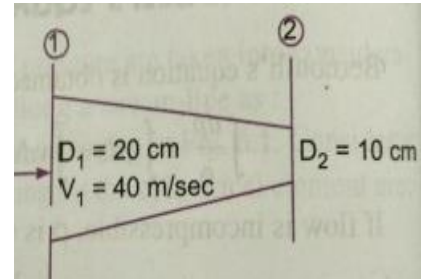

Total head = Pressure head + Kinetic head + Datum head

$$\text{Pressure head} = \frac{P}{\rho g} = \frac{29.43 \times 10^4}{1000 \times 9.81} = 30m$$

$$\text{Kinetic head} = \frac{V^2}{2g} = \frac{2 \times 2}{2 \times 9.81} = 0.204m$$

Datum head = Z = 5m

$$\frac{p}{\rho g} + \frac{V^2}{2g} + Z = 30 + 0.204 + 5 = 35.204m$$

Total head = 35.204m

PROBLEM 2. A pipe through which water is flowing is having diameters 20cms and 10cms at cross- sections 1 and 2 respectively. The velocity of water at section 1 is 4 m/sec. Find the velocity head at section 1 and 2 and also rate of discharge?

Given: D1 = 20cms = 0.2m

$$\therefore \text{Area, } A_1 = \frac{\pi}{4} D_1^2 = \frac{\pi}{4} (.2)^2 = 0.0314 \text{ m}^2$$

$$V_1 = 4.0 \text{ m/s}$$

$$D_2 = 0.1 \text{ m}$$

$$\therefore A_2 = \frac{\pi}{4} (.1)^2 = .00785 \text{ m}^2$$

i) Velocity head at section 1

$$= \frac{V_1^2}{2g} = \frac{4.0 \times 4.0}{2 \times 9.81} = 0.815 \text{ m.}$$

ii) Velocity head at section 2

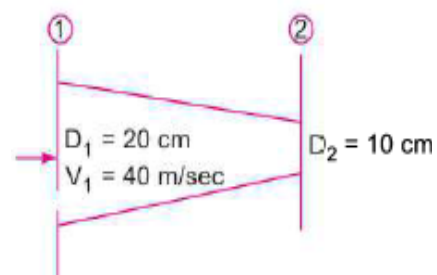



$$= V_2^2/2g$$

To find V_2 , apply continuity equation

$$A_1 V_1 = A_2 V_2$$

$$V_2 = \frac{A_1 V_1}{A_2} = \frac{.0314}{.00785} \times 4.0 = 16.0 \text{ m/s}$$

Velocity head at section 2

$$= \frac{V_2^2}{2g} = \frac{16.0 \times 16.0}{2 \times 9.81} = 83.047 \text{ m.}$$

iii) Rate of discharge

$$Q = A_1 V_1 = A_2 V_2$$

$$= 0.0314 \times 4 = 0.1256 \text{ m}^3/\text{sec}$$

$$Q = 125.6 \text{ Liters/sec}$$

PROBLEM 3. Water is flowing through a pipe having diameters 20cms and 10cms at sections 1 and 2 respectively. The rate of flow through pipe is 35 liters/sec. The section 1 is 6m above the datum and section 2 is 4m above the datum. If the pressure at section 1 is 39.24N/cm². Find the intensity of pressure at section 2?

Given: At section 1 $D_1 = 20\text{cm} = 0.2\text{m}$

At section 1, $D_1 = 20 \text{ cm} = 0.2 \text{ m}$

$$A_1 = \frac{\pi}{4} (.2)^2 = .0314 \text{ m}^2$$

$$p_1 = 39.24 \text{ N/cm}^2$$

$$= 39.24 \times 10^4 \text{ N/m}^2$$

$$z_1 = 6.0 \text{ m}$$

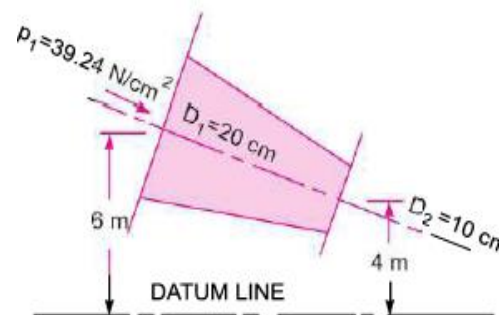

At section 2, $D_2 = 0.10 \text{ m}$

$$A_2 = \frac{\pi}{4} (0.1)^2 = .00785 \text{ m}^2$$

$$z_2 = 4 \text{ m}$$

$$p_2 = ?$$

$$\text{Rate of flow, } Q = 35 \text{ lit/s} = \frac{35}{1000} = .035 \text{ m}^3/\text{s}$$

$$Q = A_1 V_1 = A_2 V_2$$

$$V_1 = \frac{Q}{A_1} = \frac{.035}{.0314} = 1.114 \text{ m/s}$$

$$V_2 = \frac{Q}{A_2} = \frac{.035}{.00785} = 4.456 \text{ m/s}$$

Applying Bernoulli's equation at sections 1 and 2, we get

$$\frac{p_1}{\rho g} + \frac{V_1^2}{2g} + z_1 = \frac{p_2}{\rho g} + \frac{V_2^2}{2g} + z_2$$



$$\frac{39.24 \times 10^4}{1000 \times 9.81} + \frac{(1.114)^2}{2 \times 9.81} + 6.0 = \frac{p_2}{1000 \times 9.81} + \frac{(4.456)^2}{2 \times 9.81} + 4.0$$

$$40 + 0.063 + 6.0 = \frac{p_2}{9810} + 1.012 + 4.0$$

$$46.063 = \frac{p_2}{9810} + 5.012$$

$$\frac{p_2}{9810} = 46.063 - 5.012 = 41.051$$

$$p_2 = 41.051 \times 9810 \text{ N/m}^2$$

$$= \frac{41.051 \times 9810}{10^4} \text{ N/cm}^2 = \mathbf{40.27 \text{ N/cm}^2}$$

PROBLEM 4. Water is flowing through a pipe having diameter 300mm and 200mm at the bottom and upper end respectively. The intensity of pressure at the bottom end is 24.525N/cm² and the pressure at the upper end is 9.81N/cm². Determine the difference in datum head if the rate of flow through is 40lit/sec?

Given :

Section 1, $D_1 = 300 \text{ mm} = 0.3 \text{ m}$
 $p_1 = 24.525 \text{ N/cm}^2 = 24.525 \times 10^4 \text{ N/m}^2$

Section 2, $D_2 = 200 \text{ mm} = 0.2 \text{ m}$
 $p_2 = 9.81 \text{ N/cm}^2 = 9.81 \times 10^4 \text{ N/m}^2$

Rate of flow = 40 lit/s
 $Q = \frac{40}{1000} = 0.04 \text{ m}^3/\text{s}$

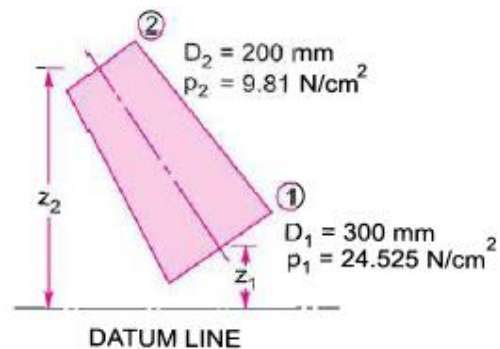

Now $A_1 V_1 = A_2 V_2 = \text{rate of flow} = 0.04$

$$\therefore V_1 = \frac{.04}{A_1} = \frac{.04}{\frac{\pi}{4} D_1^2} = \frac{0.04}{\frac{\pi}{4} (0.3)^2} = 0.5658 \text{ m/s}$$

$$\approx 0.566 \text{ m/s}$$

$$V_2 = \frac{.04}{A_2} = \frac{.04}{\frac{\pi}{4} (D_2)^2} = \frac{0.04}{\frac{\pi}{4} (0.2)^2} = 1.274 \text{ m/s}$$

Applying Bernoulli's equation at sections 1 and 2

$$\frac{p_1}{\rho g} + \frac{V_1^2}{2g} + z_1 = \frac{p_2}{\rho g} + \frac{V_2^2}{2g} + z_2$$

$$\frac{24.525 \times 10^4}{1000 \times 9.81} + \frac{.566 \times .566}{2 \times 9.81} + z_1 = \frac{9.81 \times 10^4}{1000 \times 9.81} + \frac{(1.274)^2}{2 \times 9.81} + z_2$$



$$25 + .32 + z_1 = 10 + 1.623 + z_2$$

$$25.32 + z_1 = 11.623 + z_2$$

$$\therefore z_2 - z_1 = 25.32 - 11.623 = 13.697 = 13.70 \text{ m}$$

$$\therefore \text{Difference in datum head} = z_2 - z_1 = \mathbf{13.70 \text{ m. Ans.}}$$

PROBLEM 5. The water is flowing through a taper pipe of length 100m having diameters 600mm at the upper end and 300mm at the lower end, at the rate of 50lts/sec. the pipe has a slope of 1 in 30. Find the pressure at the lower end, if the pressure at the higher level is 19.62N/cm²?

Given: Length of pipe L = 100m
 Dia. At the upper end D₁ = 600mm = 0.6m

$$\therefore \text{Area, } A_1 = \frac{\pi}{4} D_1^2 = \frac{\pi}{4} \times (.6)^2$$

$$= 0.2827 \text{ m}^2$$

$p_1 = \text{pressure at upper end}$
 $= 19.62 \text{ N/cm}^2$

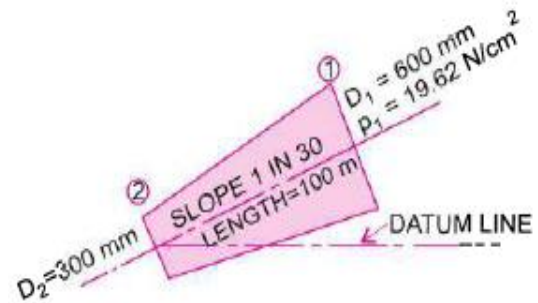

Dia. at the lower end D₂ = 300mm = 0.3m

$$\therefore \text{Area, } A_2 = \frac{\pi}{4} D_2^2 = \frac{\pi}{4} (.3)^2 = 0.07068 \text{ m}^2$$

$$Q = \text{rate of flow} = 50 \text{ litres/s} = \frac{50}{1000} = 0.05 \text{ m}^3/\text{s}$$

Let the datum line is passing through the centre of the lower end. Then Z₂ = 0

As slope is 1 in 30 means $z_1 = \frac{1}{30} \times 100 = \frac{10}{3} \text{ m}$

Also we know $Q = A_1 V_1 = A_2 V_2$

$$V_1 = \frac{Q}{A_1} = \frac{0.05}{.2827} = 0.1768 \text{ m/sec} = 0.177 \text{ m/s}$$

$$V_2 = \frac{Q}{A_2} = \frac{0.05}{.07068} = 0.7074 \text{ m/sec} = 0.707 \text{ m/s}$$

Applying Bernoulli's equation at sections 1 and 2

$$\frac{p_1}{\rho g} + \frac{V_1^2}{2g} + z_1 = \frac{p_2}{\rho g} + \frac{V_2^2}{2g} + z_2$$

$$\frac{19.62 \times 10^4}{1000 \times 9.81} + \frac{.177^2}{2 \times 9.81} + \frac{10}{3} = \frac{p_2}{\rho g} + \frac{.707^2}{2 \times 9.81} + 0$$

$$20 + 0.001596 + 3.334 = \frac{p_2}{\rho g} + 0.0254$$

$$23.335 - 0.0254 = \frac{p_2}{1000 \times 9.81}$$

$$p_2 = 23.3 \times 9810 \text{ N/m}^2 = 228573 \text{ N/m}^2 = \mathbf{22.857 \text{ N/cm}^2}. \text{ Ans.}$$





2.5 LINEAR MOMENTUM EQUATION

It is based on the law of conservation of momentum or on the momentum principle, which states that the net force acting on a fluid mass equal to the change in the momentum of the flow per unit time in that direction. The force acting on a fluid mass m , is given by Newton's second law of motion.

$$F = m \times a$$

Where 'a' is the acceleration acting in the same direction as force

But $a = \frac{dv}{dt}$

$$F = m \frac{dv}{dt} = \frac{d(mv)}{dt} \quad (\text{Since } m \text{ is a constant and can be taken inside differential})$$

$$F = \frac{d(mv)}{dt} \quad \text{is known as the momentum principle.}$$

$F \cdot dt = d(mv)$ Is known as the impulse momentum equation.

It states that the impulse of a force F acting on a fluid mass m in a short interval of time dt is equal to the change of momentum $d(mv)$ in the direction of force.

Force exerted by a flowing fluid on a pipe-bend:

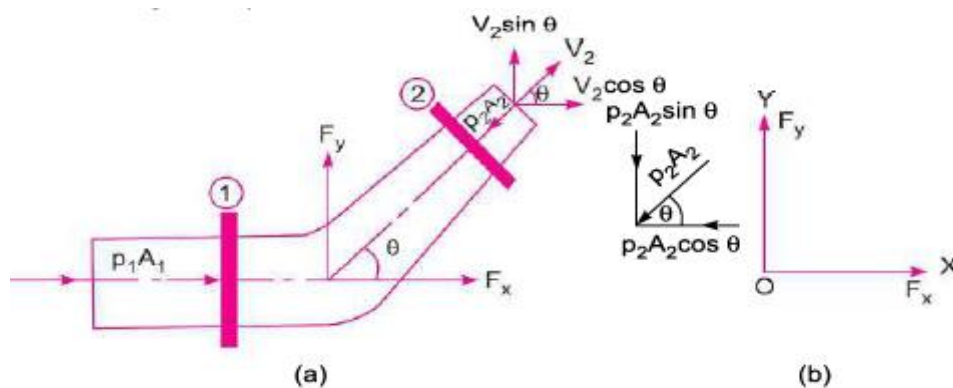

Figure 2.7.1 Forces on Bend

[Source: "Fluid Mechanics and Hydraulics Machines" by Dr.R.K.Bansal, Page: 289]

The impulse momentum equation is used to determine the resultant force exerted by a flowing fluid on a pipe bend.

Consider two sections (1) and (2) as above Let v_1 = Velocity of flow at section (1)

P_1 = Pressure intensity at section (1)

A_1 = Area of cross-section of pipe at section (1)

And V_2, P_2, A_2 are corresponding values of Velocity, Pressure, Area at section (2)

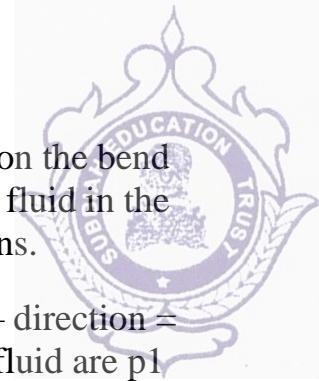

Let F_x and F_y be the components of the forces exerted by the flowing fluid on the bend in x and y directions respectively. Then the force exerted by the bend on the fluid in the directions of x and y will be equal to F_x and F_y but in the opposite directions.

Hence the component of the force exerted by the bend on the fluid in the x – direction = $- F_x$ and in the direction of $y = - F_y$. The other external forces acting on the fluid are $p_1 A_1$ and $p_2 A_2$ on the sections (1) and (2) respectively.

Then the momentum equation in x -direction is given by

Net force acting on the fluid in the direction of $x =$ Rate of change of momentum in x – direction

$$\begin{aligned}
 p_1 A_1 - p_2 A_2 \cos \theta - F_x &= (\text{Mass per second}) (\text{Change of velocity}) \\
 &= \rho Q (\text{Final velocity in } x\text{-direction} - \text{Initial velocity in } x\text{-direction}) \\
 &= \rho Q (V_2 \cos \theta - V_1) \\
 F_x &= \rho Q (V_1 - V_2 \cos \theta) + p_1 A_1 - p_2 A_2 \cos \theta \text{----- (1)}
 \end{aligned}$$

Similarly the momentum equation in y -direction gives

$$\begin{aligned}
 0 - p_2 A_2 \sin \theta - F_y &= \rho Q (V_2 \sin \theta - 0) \\
 F_y &= \rho Q (-V_2 \sin \theta) - p_2 A_2 \sin \theta \text{----- (2)}
 \end{aligned}$$

Now the resultant force (F_R) acting on the bend

$$F_R = \sqrt{F_x^2 + F_y^2}$$

And the angle made by the resultant force with the horizontal direction is given by

$$\tan \theta = \frac{F_y}{F_x}$$

PROBLEM 1. A 45° reducing bend is connected to a pipe line, the diameters at inlet and outlet of the bend being 600mm and 300mm respectively. Find the force exerted by the water on the bend, if the intensity of pressure at the inlet to the bend is 8.829N/cm^2 and rate of flow of water is 600 lts/sec.

Solution. Given :

Angle of bend, $\theta = 45^\circ$
 Dia. at inlet, $D_1 = 600 \text{ mm} = 0.6 \text{ m}$

\therefore Area, $A_1 = \frac{\pi}{4} D_1^2 = \frac{\pi}{4} (.6)^2$
 $= 0.2827 \text{ m}^2$

Dia. at outlet, $D_2 = 300 \text{ mm} = 0.30 \text{ m}$

\therefore Area, $A_2 = \frac{\pi}{4} (.3)^2 = 0.07068 \text{ m}^2$

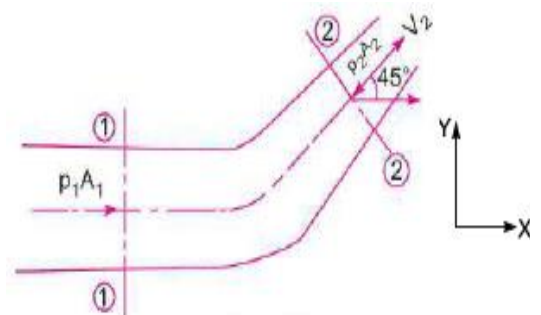



Pressure at inlet,

$$p_1 = 8.829 \text{ N/cm}^2 = 8.829 \times 10^4 \text{ N/m}^2$$

$$Q = 600 \text{ lit/s} = 0.6 \text{ m}^3/\text{s}$$

$$V_1 = \frac{Q}{A_1} = \frac{0.6}{.2827} = 2.122 \text{ m/s}$$

$$V_2 = \frac{Q}{A_2} = \frac{0.6}{.07068} = 8.488 \text{ m/s.}$$

Applying Bernoulli's equation at sections (1) and (2), we get

$$\frac{p_1}{\rho g} + \frac{V_1^2}{2g} + z_1 = \frac{p_2}{\rho g} + \frac{V_2^2}{2g} + z_2$$

But

$$z_1 = z_2$$

$$\therefore \frac{p_1}{\rho g} + \frac{V_1^2}{2g} = \frac{p_2}{\rho g} + \frac{V_2^2}{2g} \quad \text{or} \quad \frac{8.829 \times 10^4}{1000 \times 9.81} + \frac{2.122^2}{2 \times 9.81} = \frac{p_2}{\rho g} + \frac{8.488^2}{2 \times 9.81}$$

$$9 + .2295 = p_2/\rho g + 3.672$$

$$\therefore \frac{p_2}{\rho g} = 9.2295 - 3.672 = 5.5575 \text{ m of water}$$

$$\therefore p_2 = 5.5575 \times 1000 \times 9.81 \text{ N/m}^2 = 5.45 \times 10^4 \text{ N/m}^2$$

Forces on the bend in x - and y -directions

$$F_x = \rho Q [V_1 - V_2 \cos \theta] + p_1 A_1 - p_2 A_2 \cos \theta$$

$$= 1000 \times 0.6 [2.122 - 8.488 \cos 45^\circ]$$

$$+ 8.829 \times 10^4 \times .2827 - 5.45 \times 10^4 \times .07068 \times \cos 45^\circ$$

$$= -2327.9 + 24959.6 - 2720.3 = 24959.6 - 5048.2$$

$$= 19911.4 \text{ N}$$

and

$$F_y = \rho Q [-V_2 \sin \theta] - p_2 A_2 \sin \theta$$

$$= 1000 \times 0.6 [-8.488 \sin 45^\circ] - 5.45 \times 10^4 \times .07068 \times \sin 45^\circ$$

$$= -3601.1 - 2721.1 = -6322.2 \text{ N}$$

-ve sign means F_y is acting in the downward direction

$$\therefore \text{Resultant force, } F_R = \sqrt{F_x^2 + F_y^2}$$

$$= \sqrt{(19911.4)^2 + (-6322.2)^2}$$

$$= 20890.9 \text{ N. Ans.}$$

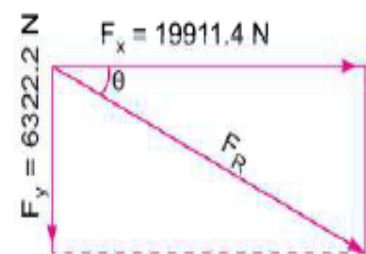



The angle made by resultant force with x -axis is given by equation

$$\tan \theta = \frac{F_y}{F_x} = \frac{6322.2}{19911.4} = 0.3175$$

\therefore

$$\theta = \tan^{-1} .3175 = 17^\circ 36'. \text{ Ans.}$$



3.1 DIMENSIONS ANALYSIS : INTRODUCTION

Dimensional analysis.

Dimensional analysis is defined as a mathematical technique used in research work for design and conducting model tests.

It is particularly useful for:

- ✓ presenting and interpreting experimental data;
- ✓ attacking problems not amenable to a direct theoretical solution;
- ✓ checking equations;
- ✓ establishing the relative importance of particular physical phenomena
- ✓ physical modelling.

Fundamental dimensions

The fundamental units quantities such as length (L), mass (M), and time (T) are fixed dimensions known as fundamental dimensions.

Units.

Unit is defined as a yardstick to measure physical quantities like distance, area, volume, mass etc.

Derive the dimensions for velocity.

Velocity is the distance (L) travelled per unit time (T)

$$\text{Velocity} = \text{Distance} / \text{Time} = [L/T] = LT^{-1}.$$

Dimensions of Derived Quantities.

Dimensions of common derived mechanical quantities are given in the following table.

S. No.	Physical Quantity	Symbol	Dimensions
(a) Fundamental			
1.	Length	L	L
2.	Mass	M	M
3.	Time	T	T
S.No.	Physical Quantity	Symbol	Dimensions
(b) Geometric			
4.	Area	A	L ²
5.	Volume	V	L ³
(c) Kinematic Quantities			
6.	Velocity	v	LT ⁻¹
7.	Angular Velocity	ω	T ⁻¹
8.	Acceleration	a	LT ⁻²
9.	Angular Acceleration	α	T ⁻²
10.	Discharge	Q	L ³ T ⁻¹
11.	Acceleration due to Gravity	g	LT ⁻²
12.	Kinematic Viscosity	ν	L ² T ⁻¹
(d) Dynamic Quantities			
13.	Force	F	MLT ⁻²
14.	Weight	W	MLT ⁻²
15.	Density	ρ	ML ⁻³
16.	Specific Weight	w	ML ⁻² T ⁻²
17.	Dynamic Viscosity	μ	ML ⁻¹ T ⁻¹
18.	Pressure Intensity	p	ML ⁻¹ T ⁻²
19.	Modulus of Elasticity	$\begin{Bmatrix} K \\ E \end{Bmatrix}$	ML ⁻¹ T ⁻²
20.	Surface Tension	σ	MT ⁻²
21.	Shear Stress	τ	ML ⁻¹ T ⁻²
22.	Work, Energy	W or E	ML ² T ⁻²
23.	Power	P	ML ² T ⁻³
24.	Torque	T	ML ² T ⁻²
25.	Momentum	M	MLT ⁻¹

TABLE 3.1.1 Dimensions of Derived Quantities



DIMENSIONAL HOMOGENEITY

Dimensional homogeneity means the dimensions of each terms in an equation on both sides are the same.

If the dimensions of each term on both sides of an equation are the same the equation is known as dimensionally homogeneous equation.

Example:

$$S = ut + \frac{1}{2} at^2$$

$$[S] = L$$

$$[ut] = [LT^{-1}T] = [L]$$

$$\left[\frac{1}{2} at^2 \right] = [LT^{-2}T^2] = [L]$$

It is a dimensionally homogeneous equation.

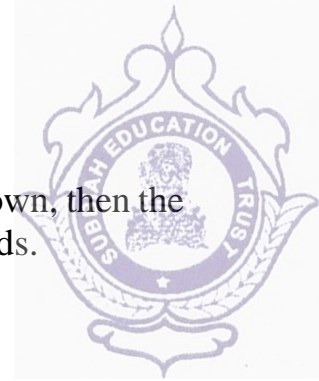

3.2 Methods of Dimensions Analysis

If the number of variables involved in a physical phenomenon are known, then the relation among the variables can be determined by the following two methods.

- Reyleigh’s method
- Buckingham’s Pi-theorem

Reyleigh’s method

This method is used for determining the expression for a variable which depends upon maximum three or four variables only. If the number of independent variables is more than five then it becomes difficult to find expression for dependent variable.

Let $X_1, X_2, X_3, \dots, X_n$ are the variables involved in a physical problem. Let X_1 be the dependent variable and X_2, X_3, \dots, X_n are independent variable upon which X_1 depends.

$$X_1 = f(X_2, X_3, \dots, X_n)$$

$$\text{i.e } f_1(X_1, X_2, X_3, \dots, X_n) = 0 \quad \text{(i)}$$

Where K is a constant and a,b,c are the arbitrary powers

Buckingham’s Pi-theorem

If there are n variables (independent and dependent) in a physical phenomenon and these variables contain m fundamental dimensions (M,L,T) then the variables are arranged into (n-m) dimensionless terms. Each term is called π term.

Let $X_1, X_2, X_3, \dots, X_n$, , are the variables involved in a physical problem. Let X_1 be the dependent variable and X_2, X_3, \dots, X_n , are independent variable upon which X_1 depends.

$$X_1 = f(X_2, X_3, \dots, X_n)$$

$$\text{i.e } f_1(X_1, X_2, X_3, \dots, X_n) = 0 \quad \text{(i)}$$

Equation (i) is dimensionally homogeneous equation. It contains n variables. If there are m fundamental dimensions then according to Buckingham’ π – Theorem, eqn.(i) can be written in terms of number of dimensionless groups or π – terms in which number of π – terms is equal to (n-m). Hence eqn.(i) becomes

$$f(\pi_1, \pi_2, \pi_3, \dots, \pi_{n-m}) = 0 \quad \text{(ii)}$$

Each π term is dimensionless and independent of the system. Division or multiplication by a constant does not change the character of the π – term. Each π – term contains m+1 variables, where m is number of fundamental dimensions and is also called repeating variables. Let in the above case X_2, X_3, X_4 are repeating variables if fundamental dimension m (M, L, T) = 3 then each π – term is written as

$$\pi_1 = X_2^{a_1} X_3^{b_1} X_4^{c_1} X_1$$

$$\pi_2 = X_2^{a_2} X_3^{b_2} X_4^{c_2} X_1$$

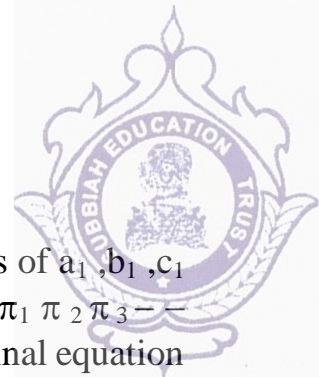

$$\pi_{n-m} = X_2^{a_{n-m}} X_3^{b_{n-m}} X_4^{c_{n-m}} X_1 \dots \dots \dots (iii)$$

Each term is solved by the principle of dimensional homogeneity and values of a_1, b_1, c_1 etc are obtained. These values are substituted in the eqn. (iii) and values of $\pi_1, \pi_2, \pi_3, \dots, \pi_{n-m}$, are obtained. These values are substituted in eqn. (ii). The final equation for the phenomenon is obtained by expressing any one of the π - terms as a function of others as

$$\pi_1 = \phi(\pi_2, \pi_3, \dots, \pi_{n-m}) = 0$$

$$\pi_2 = \phi(\pi_1, \pi_3, \dots, \pi_{n-m}) = 0$$

Method of selecting repeating variable:

1. As far as possible dependent variable should not be selected as repeating variable.
2. Repeating variables should be selected in such a way that one variable contains geometric property (such as length l , diameter d , height H etc), other variable contains flow properties (such as velocity, acceleration etc.) and the third variable contains fluid properties (such as viscosity, density etc)
3. Selected repeating variable should not form dimensionless group.
4. Repeating variables together must have same number of fundamental dimensions.
5. No two repeating variables should have the same dimension. For most of the fluid mechanics problems the choice for the repeating variable may be
 (i) d, γ, ρ (ii) l, γ, ρ (iii) l, γ, μ (iv) d, γ, μ

PROBLEM 1: A partially submerged body is towed in water. The resistance R to its motion depends on the density ρ , viscosity μ of water, length L of the body, velocity V of the body and acceleration g due to gravity. Show that the resistance to the motion can be expressed in the form of

$$R = \rho L^2 V^2 \phi \left[\left(\frac{\mu}{\rho V L} \right), \left(\frac{lg}{V^2} \right) \right]$$

Soln. The resistance R depends on ρ, μ, L, V, g

$$R = K \rho^a \cdot \mu^b \cdot l^c \cdot V^d \cdot g^e \dots(i)$$

Substituting the dimensions on both sides of the equation (i),

$$MLT^{-2} = K(ML^{-3})^a \cdot (ML^{-1}T^{-1})^b \cdot L^c \cdot (LT^{-1})^d \cdot (LT^{-2})^e$$

Equating the powers of M, L, T on both sides

Power of M ,	$1 = a + b$
Power of L ,	$1 = -3a - b + c + d + e$
Power of T ,	$-2 = -b - d - 2e.$



There are 5 unknowns and 3 equations. Expressing the three unknowns in terms of two unknowns (μ and g). Hence express a , c and d in terms of b and e . Solving we get

$$\begin{aligned} a &= 1 - b \\ d &= 2 - b - 2e \\ c &= 1 + 3a + b - d - e = 1 + 3(1 - b) + b - (2 - b - 2e) - e \\ &= 1 + 3 - 3b + b - 2 + b + 2e - e = 2 - b + e. \end{aligned}$$

Substituting these values in equation (i), we get

$$\begin{aligned} R &= K\rho^{1-b} \cdot \mu^b \cdot l^{2-b+e} \cdot V^{2-b-2e} \cdot g^e \\ &= K\rho l^2 \cdot V^2 \cdot (\rho^{-b} \mu^b l^{-b} V^{-b}) \cdot (l^e \cdot V^{-2e} \cdot g^e) \\ &= K\rho l^2 V^2 \cdot \left(\frac{\mu}{\rho V l}\right)^b \cdot \left(\frac{l g}{V^2}\right)^e \\ &= K\rho l^2 V^2 \phi \left[\left(\frac{\mu}{\rho V l}\right) \cdot \left(\frac{l g}{V^2}\right) \right]. \text{ Ans.} \end{aligned}$$

PROBLEM 2: The resisting force R of a supersonic plane during flight can be considered as dependent upon the length of the aircraft L , velocity V , air viscosity μ , air density ρ , and bulk modulus of air K . Express the functional relationship between the variables and the resisting force.

Solution. The resisting force R depends upon

- (i) density, ρ ,
- (ii) velocity, V ,
- (iii) viscosity, μ ,
- (iv) density, ρ ,
- (v) Bulk modulus, K .

$$\therefore R = A l^a \cdot V^b \cdot \mu^c \cdot \rho^d \cdot K^e \quad \dots(i)$$

Substituting the dimensions on both sides of the equation (i),

$$MLT^{-2} = AL^a \cdot (LT^{-1})^b \cdot (ML^{-1}T^{-1})^c \cdot (ML^{-3})^d \cdot (ML^{-1}T^{-2})^e$$

Equating the powers of M, L, T on both sides,

$$\begin{aligned} \text{Power of } M, & \quad 1 = c + d + e \\ \text{Power of } L, & \quad 1 = a + b - c - 3d - e \\ \text{Power of } T, & \quad -2 = -b - c - 2e. \end{aligned}$$

There are five unknowns but equations are only three. Expressing the three unknowns in terms of two unknowns (μ and K).

\therefore Express the values of a, b and d in terms of c and e .

$$\begin{aligned} \text{Solving,} \quad d &= 1 - c - e \\ b &= 2 - c - 2e \\ a &= 1 - b + c + 3d + e = 1 - (2 - c - 2e) + c + 3(1 - c - e) + e \\ &= 1 - 2 + c + 2e + c + 3 - 3c - 3e + e = 2 - c. \end{aligned}$$

Substituting these values in (i), we get

$$R = A l^{2-c} \cdot V^{2-c-2e} \cdot \mu^c \cdot \rho^{1-c-e} \cdot K^e$$



$$= A l^2 \cdot V^2 \cdot \rho (l^{-c} V^{-c} \mu^c \rho^{-c}) \cdot (V^{-2e} \cdot \rho^{-e} \cdot K^e)$$

$$= A l^2 V^2 \rho \left(\frac{\mu}{\rho V L} \right)^c \cdot \left(\frac{K}{\rho V^2} \right)^e$$

PROBLEM 3: Using Buckingham's π – Theorem show that velocity through circular orifice is given by

$$V = \sqrt{2gH} \phi \left(\frac{D}{H}, \frac{\mu}{\rho V H} \right)$$

where H is head causing flow, D is diameter of the orifice, μ is coefficient viscosity, ρ is mass density and g is acceleration due to gravity

Solution. Given :

V is a function of H, D, μ , ρ and g

$$\therefore V = f(H, D, \mu, \rho, g) \text{ or } f_1(V, H, D, \mu, \rho, g) = 0$$

$$\therefore \text{Total number of variable, } n = 6 \tag{... (i)}$$

Writing dimension of each variable, we have

$$V = LT^{-1}, H = L, D = L, \mu = ML^{-1}T^{-1}, \rho = ML^{-3}, g = LT^{-2}.$$

Thus number of fundamental dimensions, $m = 3$

$$\therefore \text{Number of } \pi\text{-terms} = n - m = 6 - 3 = 3.$$

$$\text{Equation (i) can be written as } f_1(\pi_1, \pi_2, \pi_3) = 0 \tag{... (ii)}$$

Each π -term contains $m + 1$ variables, where $m = 3$ and is also equal to repeating variables. Here V is a dependent variable and hence should not be selected as repeating variable. Choosing H, g, ρ as repeating variable, we get three π -terms as

$$\pi_1 = H^{a_1} \cdot g^{b_1} \cdot \rho^{c_1} \cdot V$$

$$\pi_2 = H^{a_2} \cdot g^{b_2} \cdot \rho^{c_2} \cdot D$$

$$\pi_3 = H^{a_3} \cdot g^{b_3} \cdot \rho^{c_3} \cdot \mu$$

First π -term $\pi_1 = H^{a_1} \cdot g^{b_1} \cdot \rho^{c_1} \cdot V$

Substituting dimensions on both sides

$$M^0 L^0 T^0 = L^{a_1} \cdot (LT^{-2})^{b_1} \cdot (MT^{-3})^{c_1} \cdot (LT^{-1})$$

Equating the powers of M, L, T on both sides,

Power of M, $0 = c,$ $\therefore c_1 = 0$

Power of L, $0 = a_1 + b_1 - 3c_1 + 1,$ $\therefore a_1 = -b_1 + 3c_1 - 1 = \frac{1}{2} - 1 = -\frac{1}{2}$

Power of T, $0 = -2b_1 - 1,$ $\therefore b_1 = -\frac{1}{2}$

Substituting the values of a_1, b_1 and c_1 in $\pi_1,$

$$\pi_1 = H^{-\frac{1}{2}} \cdot g^{-\frac{1}{2}} \cdot \rho^0 \cdot V = \frac{V}{\sqrt{gH}}.$$

Second π -term $\pi_2 = H^{a_2} \cdot g^{b_2} \cdot \rho^{c_2} \cdot D$

Substituting the dimensions on both sides,

$$M^0 L^0 T^0 = L^{a_2} \cdot (LT^{-2})^{b_2} \cdot (ML^{-3})^{c_2} \cdot L$$



Equating the powers of M, L, T ,

$$\begin{aligned} \text{Power of } M, & \quad 0 = c_2 & \quad \therefore c_2 = 0 \\ \text{Power of } L, & \quad 0 = a_2 + b_2 - 3c_2 + 1, & \quad a_2 = -b_2 + 3c_2 - 1 = -1 \\ \text{Power of } T, & \quad 0 = -2b_2, & \quad \therefore b_2 = 0 \end{aligned}$$

Substituting the values of a_2, b_2, c_2 in π_2 ,

$$\pi_2 = H^{-1} \cdot g^0 \rho^0 \cdot D = \frac{D}{H}$$

Third π -term $\pi_3 = H^{a_3} \cdot g^{b_3} \cdot \rho^{c_3} \cdot \mu$

Substituting the dimensions on both sides

$$M^0 L^0 T^0 = L^{a_3} \cdot (LT^{-2})^{b_3} \cdot (ML^{-3})^{c_3} \cdot ML^{-1} T^{-1}$$

Equating the powers of M, L, T on both sides

$$\text{Power of } M, \quad 0 = c_3 + 1, \quad \therefore c_3 = -1$$

$$\text{Power of } L, \quad 0 = a_3 + b_3 - 3c_3 - 1, \quad \therefore a_3 = -b_3 + 3c_3 + 1 = \frac{1}{2} - 3 + 1 = -\frac{3}{2}$$

$$\text{Power of } T, \quad 0 = -2b_3 - 1, \quad \therefore b_3 = -\frac{1}{2}$$

Substituting the values of a_3, b_3 and c_3 in π_3 ,

$$\pi_3 = H^{-3/2} \cdot g^{-1/2} \cdot \rho^{-1} \cdot \mu = \frac{\mu}{H^{3/2} \rho \sqrt{g}}$$

$$= \frac{\mu}{H\rho \sqrt{gH}} = \frac{\mu V}{H\rho V \sqrt{gH}} \quad \text{[Multiply and Divide by } V]$$

$$= \frac{\mu}{H\rho V} \cdot \pi_1 \quad \left\{ \because \frac{V}{\sqrt{gH}} = \pi_1 \right\}$$

Substituting the values of π_1, π_2 and π_3 in equation (ii),

$$f_1 \left(\frac{V}{\sqrt{gH}}, \frac{D}{H}, \pi_1 \frac{\mu}{H\rho V} \right) = 0 \text{ or } \frac{V}{\sqrt{gH}} = \phi \left[\frac{D}{H}, \pi_1 \frac{\mu}{H\rho V} \right]$$

or
$$V = \sqrt{2gH} \phi \left[\frac{D}{H}, \frac{\mu}{\rho V H} \right]. \text{ Ans.}$$

Multiplying by a constant does not change the character of π -terms.



3.3 DIMENSIONLESS NUMBERS

In fluid mechanics, Dimensionless numbers or non-dimensional numbers are those which are useful to determine the flow characteristics of a fluid. Inertia force always exists if there is any mass in motion. Dividing this inertia force with other forces like viscous force, gravity force, surface tension, elastic force, or pressure force, gives us the dimensionless numbers.

Dimensionless Numbers in Fluid Mechanics

Some important dimensionless numbers used in fluid mechanics and their importance is explained below.

1. Reynolds Number
2. Froude Number
3. Weber Number
4. Mach Number
5. Euler's Number

1. Reynolds number

Reynolds number is the ratio of inertia force to the viscous force. It describes the predominance of inertia forces to the viscous forces occurring in the flow systems.

$$R_e = \frac{\rho \cdot v \cdot d}{\mu}$$

Where,

ρ = Density of fluid (kg/m³)

μ = viscosity of fluid (kg/m.s)

d = diameter of pipe (m)

v = velocity of flow (m/s)

Importance

Reynolds number is applicable for closed surface flows as well as for free surface flows. Some applications where Reynolds number is significant for finding the flow behavior are incompressible flow through small pipes, the motion of a submarine completely under water, flow through low-speed turbomachines, etc.



2. Froude number

Froude number is the ratio of inertia force to the gravitational force. Froude number is significant in case of free surface flows where the gravitational force is predominant compared to other forces.

$$F_r = \frac{v}{\sqrt{g \cdot L}}$$

Where,

L = length of flow (m)

v = velocity of flow (m/s)

g = acceleration due to gravity (m/s²)

Importance

Froude number is useful to describe the flow in open channels, flow over notches and weirs, the motion of a ship in turbulent sea conditions (ship resistance), flow over spillways, etc.

3. Weber number

Weber number is the ratio of inertia force to the surface tension. The formation of droplets or water bubbles in a fluid is normally due to surface tension. If Weber number is small, surface tension is larger and vice versa.

$$W_e = \frac{\rho \cdot d \cdot v^2}{\sigma}$$

Applications

Weber number is less than 1 when surface tension is predominant. It happens when the curvature of the liquid surface is small compared to its depth. This can be seen in different situations such as the flow of blood in veins and arteries, atomization of liquids, capillary flow of water in soils, thin layers of fluid passing over surface, etc.

4. Mach number

Mach number is the ratio of inertia force to the elastic force. If the Mach number is one, then the flow velocity is equal to the velocity of sound in the fluid. If it is less than one, then the flow is called subsonic flow, and if it is greater than one the flow is called supersonic flow.



$$M_a = \frac{v}{c}$$

Where,

v = Velocity of flow (m/s)

c = Velocity of sound in fluid (m/s)

Applications

Mach number is useful to describe problems in high flow velocities. It is also used in aerodynamics to describe the speed of jet plane or missile in terms of speed of sound.

5. Euler's number

Euler number is the ratio of pressure force to the inertia force.

$$E_u = \frac{F}{\rho \cdot v^2 \cdot L^2}$$

Where,

F = pressure force

ρ = Density of fluid (kg/m³)

L = Characteristic length of flow (m)

v = velocity of flow (m/s)

Applications

Euler's number is significant in cases where pressure gradient exists such as flow through pipes, water hammer pressure in penstocks, discharge through orifices and mouthpieces, etc.



3.4 MODEL STUDIES

Model: Model is the small scale replica of the actual structure or machine. It is not necessary that models should be smaller than the prototypes (although in most of the cases it is), they may be larger than the prototypes.

Prototype: The actual structure or machine

Model analysis: Model analysis is the study of models of actual machine.

Advantages:

- The performance of the machine can be easily predicted, in advance.
- With the help of dimensional analysis, a relationship between the variables influencing a flow problem in terms of dimensional parameters is obtained. This relationship helps in conducting tests on the model.
- The merits of alternative designs can be predicted with the help of model testing. The most economical and safe design may be, finally, adopted.

Type of forces acting in the moving fluid

Inertial force: it is equal to the mass and acceleration of the moving fluid.

$$F_i = \rho AV^2$$

Viscous force: it is equal to the shear stress due to viscosity and surface area of the flow. It is present in the flow problems where viscosity is having an important role to play.

$$F_v = \tau A = \mu \frac{du}{dy} A = \mu \frac{U}{d} A$$

Gravity force: product of mass and acceleration due to gravity.

$$F_g = \rho ALg$$

Pressure force: product of pressure intensity and flow area.

$$F_p = pA$$

Surface tension force: product of surface tension and the length of the surface of the flowing fluid.

$$F_s = \sigma d$$

Elastic force: product of elastic stress and area of the flow.

$$F_e = \text{Elastic stress} \times \text{Area} = KA$$



Classification of model

- Undistorted models: are those models which are geometrically similar to their prototype. In other words the scale ratio for the linear dimensions of the model and its prototype are the same.
- Distorted models: are those models which are geometrically not similar to its prototype. In other words the scale ratio for the linear dimensions of the model and its prototype are not same.

For example river: If the horizontal and vertical scale ratios for the model and the prototype are same then it is undistorted model. In this case the depth of the water in the model becomes very small which may not be measured accurately.

Thus for cases distorted model is useful.

The followings are the advantages of distorted models

- ✓ The vertical dimension of the model can be accurately measured
- ✓ The cost of the model can be reduced
- ✓ Turbulent flow in the model can be maintained

Though there are some advantage of distorted models, however the results of such models cannot be directly transferred to prototype.

Scale Ratios for Distorted Models

Let: $(L_r)_H = \frac{L_p}{L_m} = \frac{B_p}{B_m}$ Scale ratio for horizontal direction

$(L_r)_V = \frac{h_p}{h_m}$ Scale ratio for vertical direction

Scale Ratio for Velocity: $V_r = V_p / V_m = \frac{\sqrt{2gh_p}}{\sqrt{2gh_m}} = \sqrt{(L_r)_V}$

Scale Ratio for area of flow: $A_r = A_p / A_m = \frac{B_p h_p}{B_m h_m} = (L_r)_H (L_r)_V$

Scale Ratio for discharge: $Q_r = Q_p / Q_m = \frac{A_p V_p}{A_m V_m} = (L_r)_H (L_r)_V \sqrt{(L_r)_V} = (L_r)_H (L_r)_V^{3/2}$

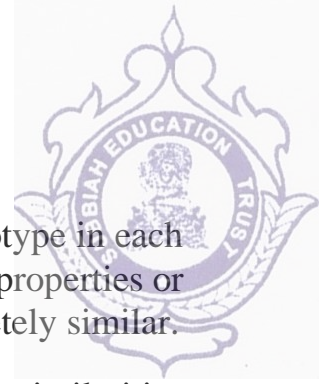

3.5 SIMILITUDES AND MODEL LAWS

Similitude is basically defined as the similarity between model and its prototype in each and every respect. It suggests us that model and prototype will have similar properties or we can say that similitude explains that model and prototype will be completely similar.

Three types of similarities must exist between model and prototype and these similarities are as mentioned here.

Geometric similarity

Kinematic similarity

Dynamic similarity

Geometric similarity

Geometric similarity is the similarity of shape. Geometric similarity is said to exist between model and prototype, if the ratio of all respective linear dimension in model and prototype are equal.

Ratio of dimension of model and corresponding dimension of prototype will be termed as scale ratio i.e. L_r .

Let us assume the following linear dimension in model and prototype.

$$\frac{L_p}{L_m} = \frac{B_p}{B_m} = \frac{D_p}{D_m} = L_r$$

$$\frac{A_p}{A_m} = L_r^2$$

$$\frac{V_p}{V_m} = L_r^3$$

where L_r is Scale Ratio

L_m = Length of model, L_p = Length of prototype

B_m = Breadth of model, B_p = Breadth prototype

D_m = Diameter of model, D_p = Diameter of prototype

A_m = Area of model, A_p = Area of prototype

V_m = Volume of model, V_p = Volume of prototype

Kinematic Similarity

The Kinematic similarity is said to exist between model and prototype, if the ratios of velocity and acceleration at a point in model and at the respective point in the prototype are the same.



We must note it here that the direction of velocity and acceleration in the model and prototype must be identical.

$$\frac{V_p}{V_m} = V_r$$

$$\frac{a_p}{a_m} = a_r$$

where V_r is Velocity Ratio

where a_r is Acceleration Ratio

V_m = Velocity of fluid at a point in model

V_p = Velocity of fluid at respective point in prototype

a_m = Acceleration of fluid at a point in model

a_p = Acceleration of fluid at respective point in prototype

Dynamic Similarity

The dynamic similarity is said to exist between model and prototype, if the ratios of corresponding forces acting at the corresponding points are the same.

We must note it here that the direction of forces at the corresponding points in the model and prototype must be same.

$$\frac{F_p}{F_m} = F_r$$

where F_r is Force Ratio

F_m = Force at a point in model, F_p = Force at respective point in prototype

Model laws or similarity laws

For the dynamic similarity between the model and the prototype, ratio of corresponding forces acting on corresponding points in the model and the prototype should be same.

Ratios of the forces are dimensionless numbers. Therefore we can say that for the dynamic similarity between the model and the prototype, dimensionless numbers should be equal for the model and the prototype.

However, it is quite difficult to satisfy the condition that all the dimensionless numbers should be equal for the model and the prototype.

However for practical problems, it is observed that one force will be most significant as compared to others and that force is considered as predominant force. Therefore for dynamic similarity, predominant force will be considered in practical problems.



Therefore, models are designed on the basis of ratio of force which is dominating in the phenomenon.

Hence, we can define the model laws or similarity laws as the law on which models are designed for the dynamic similarity.

There are following types of model laws

Reynold's Model law

Froude Model law

Euler Model law

Weber Model law

Mach Model law

Reynold's Model law

Reynold's model law could be defined as a model law or similarity law where models are designed on the basis of Reynold's numbers.

According to the Reynold's model law, for the dynamic similarity between the model and the prototype, Reynold's number should be equal for the model and the prototype.

In simple, we can say that Reynold's number for the model must be equal to the Reynold's number for the prototype.

As we know that Reynold's number is basically the ratio of inertia force and viscous force, therefore a fluid flow situation where viscous forces are alone predominant, models will be designed on the basis of Reynold's model law for the dynamic similarity between the model and the prototype.

$$(\text{Re})_p = (\text{Re})_m \text{ or } \frac{V_p L_p}{\nu_p} = \frac{V_m L_m}{\nu_m}$$

Where,

V_m = Velocity of the fluid in the model

L_m = Length of the model

ν_m = Kinematic viscosity of the fluid in the model

V_p = Velocity of the fluid in the prototype

L_p = Length of the prototype

ν_p = Kinematic viscosity of the fluid in the prototype



Models based on the Reynold's model law

Pipe flow

Resistance experienced by submarines, airplanes etc.

Froude Model law

Froude model law could be defined as a model law or similarity law where models are designed on the basis of Froude numbers.

According to the Froude model law, for the dynamic similarity between the model and the prototype, Froude number should be equal for the model and the prototype.

In simple, we can say that Froude number for the model must be equal to the Froude number for the prototype.

As we know that Froude number is basically the ratio of inertia force and gravity force, therefore a fluid flow situation where gravity forces are alone predominant, models will be designed on the basis of Froude model law for the dynamic similarity between the model and the prototype.

$$(F e)_p = (F e)_m \text{ or } \frac{V_p}{\sqrt{g_p L_p}} = \frac{V_m}{\sqrt{g_m L_m}}$$

Where,

V_m = Velocity of the fluid in the model

L_m = Length of the model

g_m = Acceleration due to gravity at a place where model is tested

V_p = Velocity of the fluid in the prototype

L_p = Length of the prototype

g_p = Acceleration due to gravity at a place where prototype is tested

Models based on the Froude model law

Free surface flows such as flow over spillways, weirs, sluices, channels etc,

Flow of jet from an orifice or from a nozzle,

Where waves are likely to be formed on surface

Where fluids of different densities flow over one another



Euler's Model law

Euler's model law could be defined as a model law or similarity law where models are designed on the basis of Euler's numbers.

According to the Euler's model law, for the dynamic similarity between the model and the prototype, Euler's number should be equal for the model and the prototype.

In simple, we can say that Euler's number for the model must be equal to the Euler's number for the prototype.

As we know that Euler's number is basically the ratio of pressure force and inertia force, therefore a fluid flow situation where pressure forces are alone predominant, models will be designed on the basis of Euler's model law for the dynamic similarity between the model and the prototype.

$$\frac{V_m}{\sqrt{P_m / \rho_m}} = \frac{V_p}{\sqrt{P_p / \rho_p}}$$

Where,

V_m = Velocity of the fluid in the model

P_m = Pressure of fluid in the model

ρ_m = Density of the fluid in the model

V_p = Velocity of the fluid in the prototype

P_p = Pressure of fluid in the prototype

ρ_p = Density of the fluid in the prototype

Models based on the Euler's model law

Euler's model law will be applicable for a fluid flow situation where flow is taking place in a closed pipe, in which case turbulence will be fully developed so that viscous forces will be negligible and gravity force and surface tension force will be absent.

Weber Model law

Weber model law could be defined as a model law or similarity law where models are designed on the basis of Weber numbers.

According to the Weber model law, for the dynamic similarity between the model and the prototype, Weber number should be equal for the model and the prototype.

In simple, we can say that Weber number for the model must be equal to the Weber number for the prototype.



As we know that Weber number is basically the ratio of inertia force and surface tension force, therefore a fluid flow situation where surface tension forces are alone predominant, models will be designed on the basis of Weber model law for the dynamic similarity between the model and the prototype.

$$\frac{V_m}{\sqrt{\sigma_m / \rho_m L_m}} = \frac{V_p}{\sqrt{\sigma_p / \rho_p L_p}}$$

Where,

V_m = Velocity of the fluid in the model

σ_m = Surface tension force in the model

ρ_m = Density of the fluid in the model

L_m = Length of surface in the model

V_p = Velocity of the fluid in the prototype

σ_p = Surface tension force in the prototype

ρ_p = Density of the fluid in the prototype

L_p = Length of surface in the prototype

Models based on the Weber model law

Capillary rise in narrow passage

Capillary movement of water in soil

Capillary waves in channels

Flow over weirs for small heads

Mach Model law

Mach model law could be defined as a model law or similarity law where models are designed on the basis of Mach numbers.

According to the Mach model law, for the dynamic similarity between the model and the prototype, Mach number should be equal for the model and the prototype.

In simple, we can say that Mach number for the model must be equal to the Mach number for the prototype.

As we know that Mach number is basically the ratio of inertia force and Elastic force, therefore a fluid flow situation where elastic forces are alone predominant, models will



be designed on the basis of Mach model law for the dynamic similarity between the model and the prototype.

$$\frac{V_m}{\sqrt{K_m / \rho_m}} = \frac{V_p}{\sqrt{K_p / \rho_p}}$$

Where,

V_m = Velocity of the fluid in the model

K_m = Elastic stress for model

ρ_m = Density of the fluid in the model

V_p = Velocity of the fluid in the prototype

K_p = Elastic stress for prototype

ρ_p = Density of the fluid in the prototype

Models based on the Mach model law

Water hammer problems

Under water testing of torpedoes

Aerodynamic testing

Flow of aeroplane and projectile through air at supersonic speed

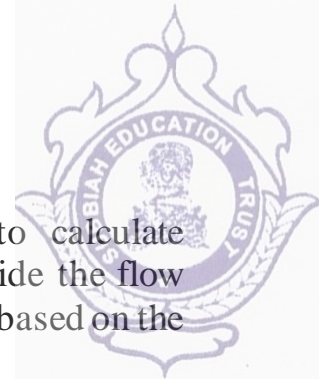

4.1 REYNOLD'S EXPERIMENT

As we are aware that for determining the type of flow we use to calculate the Reynolds number and on the basis of Reynolds number we use to decide the flow type. So let us see here the basics behind the determination of type of flow based on the Reynolds number.

Value for Reynolds number might be calculated with the help of following formula

$$Re = \rho V D / \mu$$

Where,

V = Flow velocity of the Hydraulic fluid i.e. liquid (m/s)

D = Diameter of pipe (m)

μ = viscosity (poise)

O Reynold had explained this concept with one experiment, which is explained here, in 1883. Reynold had concluded that transition from laminar flow to turbulent flow in a pipe depends not only on the velocity but also it depends on the diameter of the pipe and viscosity of the fluid flowing through the pipe.

Reynolds experiment apparatus

Apparatus for Reynolds experiment are as mentioned here

1. A tank containing water at constant head
2. A small tank containing some dye
3. A glass tube with bell-mouthed entrance at one end and a regulating valve at other end

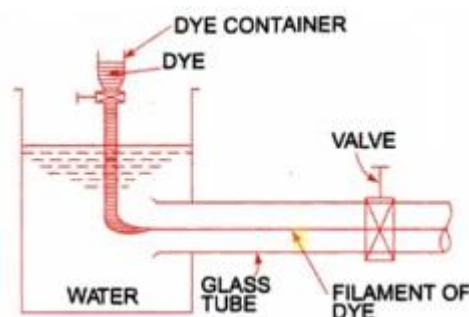

Figure 4.1.1 Apparatus for Reynolds experiment

[Source: "Fluid Mechanics and Hydraulics Machines" by Dr.R.K.Bansal, Page: 442]



Now we will allow water to pass through the glass tube from the water tank. Regulating valve is provided here to vary the velocity of water flowing through the glass tube.

We will introduce a liquid dye, of having same specific weight as of water, in to the glass tube as displayed here in following figure.

Observations made by Reynold

Observation I

When velocity of water flow is low, dye filament will be in the form of straight line in the glass tube. It could be seen in the glass tube that dye filament is in the form of straight line and parallel to the wall of glass tube.

Above condition is the example of laminar fluid flow. Therefore at lower velocity of water flow through the glass tube, the type of water flow will be laminar.

Following figure, displayed here as figure a, indicates the case of water flow through the glass tube at low velocity of water flow.

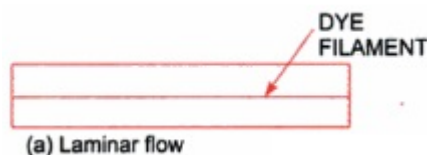

Observation II

Now velocity of flow is increased with the help of regulating valve. Dye filament will not be in the form of straight line in the glass tube. It could be seen in the glass tube that dye filament is in the form of wavy one now.

Above condition is the example of transition of fluid flow. Therefore when velocity of water flow through the glass tube is increased, the type of water flow will be transition flow. Transition flow means the flow between laminar flow and turbulent flow.

Following figure, displayed here as figure b, indicates the case of transition flow through the glass tube.



Observation III

Now velocity of flow is increased again with the help of regulating valve. Wavy dye filament will be broken and finally diffused in the water as displayed here in following figure.

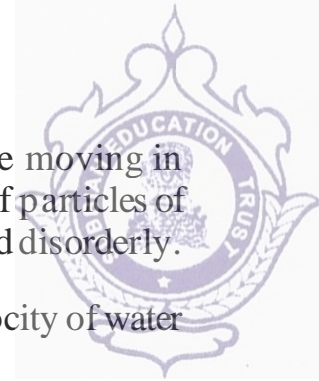

It could be seen in the glass tube that particles of dye filament liquid are moving in random and irregular fashion at this higher velocity of water flow. Mixing of particles of water and dye filament is intense and water flow will be random, irregular and disorderly.

Above condition is the example of turbulent fluid flow. Therefore when velocity of water flow will be higher, the type of water flow will be turbulent flow.

Following figure, displayed here as figure c, indicates the case of turbulent flow through the glass tube.

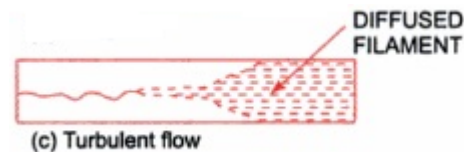

In case of laminar fluid flow, loss of pressure head will be proportional to the velocity of fluid flow.

While in case of turbulent fluid flow, loss of pressure head will be approximately proportional to the square of velocity of fluid flow.

The Reynolds number is a very useful parameter in predicting whether the flow is laminar or turbulent.

$Re < 2000$ viscous / laminar flow

$Re \rightarrow 2000$ to 4000 Transient flow

$Re > 4000$ Turbulent flow



4.2 HYDRAULIC AND ENERGY GRADIENT

Concepts of hydraulic gradient line and total energy line will be quite useful when we analyze the problems of fluid flow through pipes.

Hydraulic gradient line and total energy line are the graphical representation for the longitudinal variation in piezometric head and total head.

Hydraulic gradient line

Hydraulic gradient line is basically defined as the line which will give the sum of pressure head and datum head or potential head of a fluid flowing through a pipe with respect to some reference line.

Hydraulic gradient line = Pressure head + Potential head or datum head

$$\text{H.G.L} = P/\rho g + Z$$

Where,

H.G.L = Hydraulic gradient line

$P/\rho g$ = Pressure head

Z = Potential head or datum head

Total Energy Line

Total energy line is basically defined as the line which will give the sum of pressure head, potential head and kinetic head of a fluid flowing through a pipe with respect to some reference line.

Total energy line = Pressure head + Potential head + Kinetic head

$$\text{H.G.L} = P/\rho g + Z + V^2/2g$$

Where,

T.E.L = Total energy line

$P/\rho g$ = Pressure head

Z = Potential head or datum head

$V^2/2g$ = Kinetic head or velocity head



Relation between hydraulic gradient line and total energy line

$$\text{H.G.L} = \text{E.G.L} - \frac{V^2}{2g}$$

Let us see the following figure, there is one reservoir filled with water and also connected with one pipe of uniform cross-sectional diameter.

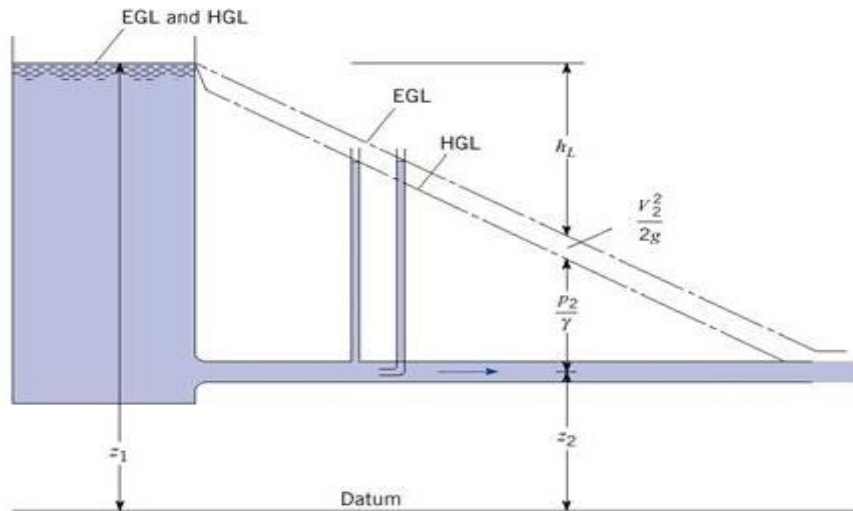

Hydraulic gradient and energy lines are displayed in figure.

At Velocity $V = 0$, Kinetic head will be zero and therefore hydraulic gradient line and energy gradient line will be same.

At Velocity $V = 0$, $\text{EGL} = \text{HGL}$



4.3 FRICTIONAL LOSS IN PIPE FLOW – DARCY WEISBACK EQUATION

When a liquid is flowing through a pipe, the velocity of the liquid layer adjacent to the pipe wall is zero. The velocity of liquid goes on increasing from the wall and thus velocity gradient and hence shear stresses are produced in the whole liquid due to viscosity. This viscous action causes loss of energy, which is known as frictional loss.

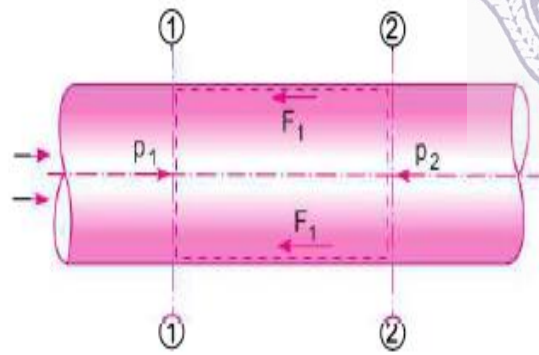

Consider a uniform horizontal pipe having steady flow. Let 1-1, 2-2 are two sections of pipe.

Let P_1 = Pressure intensity at section 1-1

V_1 = Velocity of flow at section 1-1

L = Length of pipe between section 1-1 and 2-2

d = Diameter of pipe

f' = Fractional resistance for unit wetted area per a unit velocity

h_f = Loss of head due to friction

And P_2, V_2 = are values of pressure intensity and velocity at section 2-2

Applying Bernoulli’s equation between sections 1-1 and 2-2

Total head at 1-1 = total head at 2-2 + loss of head due to friction between 1-1 and 2-2

$$\frac{P_1}{\rho g} + \frac{V_1^2}{2g} + z_1 = \frac{P_2}{\rho g} + \frac{V_2^2}{2g} + z_2 + h_f$$

But

$z_1 = z_2$ as pipe is horizontal

$V_1 = V_2$ as dia. of pipe is same at 1-1 and 2-2

$$\therefore \frac{P_1}{\rho g} = \frac{P_2}{\rho g} + h_f \text{ or } h_f = \frac{P_1}{\rho g} - \frac{P_2}{\rho g} \quad \dots(i)$$

But h_f is head is lost due to friction and hence the intensity of pressure will be reduced in the direction flow by frictional resistance.

Now, Frictional Resistance = Frictional resistance per unit wetted area per unit velocity unit velocity \times Wetted Area \times (velocity)²

$$F_1 = f' \times \pi d L \times V^2 \quad [\because \text{wetted area} = \pi d \times L, \text{ velocity} = V = V_1 = V_2]$$

$$= f' \times P \times L \times V^2 \quad [\because \pi d = \text{Perimeter} = P] \dots(ii)$$

The forces acting on the fluid between section 1-1 and 2-2 are



Pressure force at section 1-1 = $P_1 \times A$ where A = area of pipe

Pressure force at section 2-2 = $P_2 \times A$

Frictional force = F_1

Resolving all forces in the horizontal direction, we have

$$p_1A - p_2A - F_1 = 0$$

or
$$(p_1 - p_2)A = F_1 = f' \times P \times L \times V^2$$

[\because From (ii), $F_1 = f'PLV^2$]

or
$$p_1 - p_2 = \frac{f' \times P \times L \times V^2}{A}$$

But from equation (i), $p_1 - p_2 = \rho gh_f$

Equating the value of $P_1 - P_2$, we get

$$\rho gh_f = \frac{f' \times P \times L \times V^2}{A}$$

$$h_f = \frac{f'}{\rho g} \times \frac{P}{A} \times L \times V^2 \quad \dots(iii)$$

In equation (iii), $\frac{P}{A} = \frac{\text{Wetted perimeter}}{\text{Area}} = \frac{\pi d}{\frac{\pi}{4}d^2} = \frac{4}{d}$

$$\therefore h_f = \frac{f'}{\rho g} \times \frac{4}{d} \times L \times V^2 = \frac{f'}{\rho g} \times \frac{4LV^2}{d} \quad \dots(iv)$$

Putting $\frac{f'}{\rho} = \frac{f}{2}$, where f is known as co-efficient of friction.

Equation (iv), becomes as
$$h_f = \frac{4 \cdot f}{2g} \cdot \frac{LV^2}{d} = \frac{4f \cdot L \cdot V^2}{d \times 2g}$$

$$h_f = \frac{f \cdot L \cdot V^2}{d \times 2g}$$

This Equation is known as Darcy – Weisbach equation, commonly used for finding loss of head due to friction in pipes

Then f is known as a friction factor or co-efficient of friction which is a dimensionless quantity. f is not a constant but, its value depends upon the roughness condition of pipe surface and the Reynolds number of the flow.





4.3 FRICTIONAL LOSS IN PIPE FLOW – DARCY WEISBACK EQUATION

When a liquid is flowing through a pipe, the velocity of the liquid layer adjacent to the pipe wall is zero. The velocity of liquid goes on increasing from the wall and thus velocity gradient and hence shear stresses are produced in the whole liquid due to viscosity. This viscous action causes loss of energy, which is known as frictional loss.

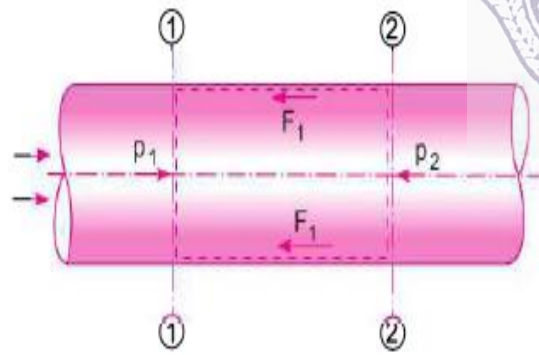

Consider a uniform horizontal pipe having steady flow. Let 1-1, 2-2 are two sections of pipe.

Let P_1 = Pressure intensity at section 1-1

V_1 = Velocity of flow at section 1-1

L = Length of pipe between section 1-1 and 2-2

d = Diameter of pipe

f' = Fractional resistance for unit wetted area per a unit velocity

h_f = Loss of head due to friction

And P_2, V_2 = are values of pressure intensity and velocity at section 2-2

Applying Bernoulli’s equation between sections 1-1 and 2-2

Total head at 1-1 = total head at 2-2 + loss of head due to friction between 1-1 and 2-2

$$\frac{p_1}{\rho g} + \frac{V_1^2}{2g} + z_1 = \frac{p_2}{\rho g} + \frac{V_2^2}{2g} + z_2 + h_f$$

But

$z_1 = z_2$ as pipe is horizontal

$V_1 = V_2$ as dia. of pipe is same at 1-1 and 2-2

$$\therefore \frac{p_1}{\rho g} = \frac{p_2}{\rho g} + h_f \text{ or } h_f = \frac{p_1}{\rho g} - \frac{p_2}{\rho g} \quad \dots(i)$$

But h_f is head is lost due to friction and hence the intensity of pressure will be reduced in the direction flow by frictional resistance.

Now, Frictional Resistance = Frictional resistance per unit wetted area per unit velocity unit velocity \times Wetted Area \times (velocity)²

$$F_1 = f' \times \pi d L \times V^2 \quad [\because \text{wetted area} = \pi d \times L, \text{ velocity} = V = V_1 = V_2]$$

$$= f' \times P \times L \times V^2 \quad [\because \pi d = \text{Perimeter} = P] \dots(ii)$$

The forces acting on the fluid between section 1-1 and 2-2 are



Pressure force at section 1-1 = $P_1 \times A$ where A = area of pipe

Pressure force at section 2-2 = $P_2 \times A$

Frictional force = F_1

Resolving all forces in the horizontal direction, we have

$$p_1A - p_2A - F_1 = 0$$

or
$$(p_1 - p_2)A = F_1 = f' \times P \times L \times V^2$$

[\because From (ii), $F_1 = f'PLV^2$]

or
$$p_1 - p_2 = \frac{f' \times P \times L \times V^2}{A}$$

But from equation (i), $p_1 - p_2 = \rho gh_f$

Equating the value of $P_1 - P_2$, we get

$$\rho gh_f = \frac{f' \times P \times L \times V^2}{A}$$

$$h_f = \frac{f'}{\rho g} \times \frac{P}{A} \times L \times V^2 \quad \dots(iii)$$

In equation (iii), $\frac{P}{A} = \frac{\text{Wetted perimeter}}{\text{Area}} = \frac{\pi d}{\frac{\pi}{4}d^2} = \frac{4}{d}$

$$\therefore h_f = \frac{f'}{\rho g} \times \frac{4}{d} \times L \times V^2 = \frac{f'}{\rho g} \times \frac{4LV^2}{d} \quad \dots(iv)$$

Putting $\frac{f'}{\rho} = \frac{f}{2}$, where f is known as co-efficient of friction.

Equation (iv), becomes as
$$h_f = \frac{4 \cdot f}{2g} \cdot \frac{LV^2}{d} = \frac{4f \cdot L \cdot V^2}{d \times 2g}$$

$$h_f = \frac{f \cdot L \cdot V^2}{d \times 2g}$$

This Equation is known as Darcy – Weisbach equation, commonly used for finding loss of head due to friction in pipes

Then f is known as a friction factor or co-efficient of friction which is a dimensionless quantity. f is not a constant but, its value depends upon the roughness condition of pipe surface and the Reynolds number of the flow.





4.4 MAJOR AND MINOR LOSSES OF FLOW IN PIPES

Major Losses

The major losses of energy are due to friction. Which are considerable hence it is called as major losses. It is determined by Darcy- Weisbach formula and Chezy's formula. Head loss due to friction is denoted by h_f .

Darcy- Weisbach formula

$$h_f = \frac{4 f L V^2}{2 g d}$$

Where, h_f – loss of head due to friction in meter of fluid

f - Coefficient of friction

Coefficient of friction is function of Reynolds's Number (Re).

If Re is less than 2000 (i.e. laminar flow) $f = \frac{16}{Re}$

If Re is greater than 4000 (i.e. turbulent flow) $f = \frac{0.0719}{Re^{1/4}}$ L- Length of pipe in m.

V- Velocity of flow in m/s.

d- Diameter of pipe in m.

Let, $V = \frac{Q}{A}$, Hence Darcy-Weisbach formula in the term of discharge Q,

$$h_f = \frac{f L Q^2}{12 d^5}$$

Chezy's formula-

$$V = C \sqrt{m i}$$

Where V – velocity of flow in m/s

C – Chezy's constant

i – Loss of head per unit length of pipe = $\frac{h_f}{L}$

m – Hydraulic mean depth = (Area of flow/ Perimeter) = A / P

$m = \frac{d}{4}$ for pipe flow

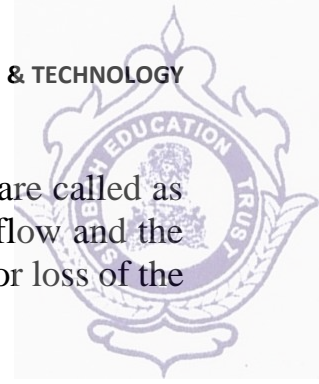

Minor losses

The losses due to disturbances in flow pattern or due to change in velocity are called as minor losses. These losses may occur due to sudden change in the area of flow and the direction of flow. These losses are less as compare to major losses. The minor loss of the head (energy) includes the following cases:

1. Loss of head due to sudden enlargement
2. Loss of head due to sudden contraction
3. Loss of head at the entrance of a pipe
4. Loss of head at the exit of a pipe
5. Loss of head due to bends
6. Loss of head in various pipe fittings
7. Loss of head due to obstruction

1. Loss of head due to sudden enlargement

Fig. represents a pipe in which fluid experiences sudden enlargement. Here the head loss occurs due to the separation of the flow at the periphery of the smaller pipe, which leads to eddying motion in the corner region.

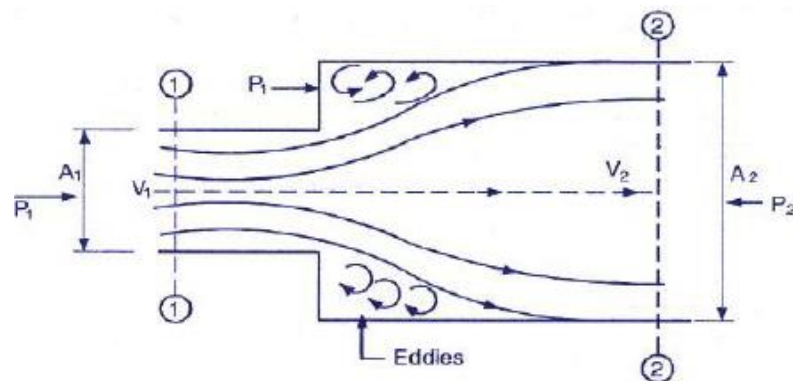

The Equation gives head loss due to sudden expansion.

$$h_e = \frac{(V_1 - V_2)^2}{2g}$$

Where, V_1 = Velocity of fluid at section 1-1

V_2 = Velocity of fluid at section 2-2

2. Loss of Head Due to Sudden Contraction

Fig. represents a pipe in which fluid experiences sudden contraction. The stream lines are converging from section 1-1 to section C-C. The head loss occurs only after the vena contracta CC. This is because the flow up to this section is accelerating and the boundary layer separation does not occur.

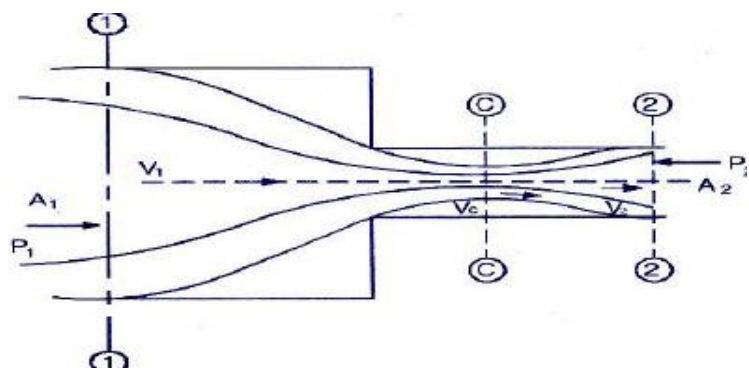



Using Bernoulli's equation, continuity and momentum equation at section 1-1 and 2-2, it can be proved that head loss due to sudden contraction is,

$$h_c = \left(\frac{1}{c_c} - 1 \right)^2 \frac{v_2^2}{2g}$$

Where, V_2 = Velocity of fluid at section 2-2

C_c = Coefficient of contraction = A_c / A_2

If C_c not given,

$$h_c = 0.5 \frac{v_2^2}{2g}$$

3. Loss of Head at the entrance of a pipe

The loss of head at the entrance of pipe is a similar case to loss of head due to sudden contraction as there is an abrupt reduction in area from an area of reservoir to area of a pipe. The loss of head is caused mainly by the turbulence created by the sudden enlargement of the jet after it has passed through the vena contracta.

$$h = 0.5 \frac{v^2}{2g}$$

4. Loss of head at the exit of a pipe

When the fluid from the pipe enters into a relatively larger reservoir the entire velocity is dissipated. If V is the velocity of fluid in a pipe, the head loss at exit is given by

$$h = \frac{v^2}{2g}$$

5. Loss of head due to bends

The loss of head in bends provided in pipes may be expressed as,

$$h = k \frac{v^2}{2g}$$

V is the mean velocity of flow of liquid and K = coefficient of bend and is depends on the angle of bend, radius of the curvature and diameter of pipe.

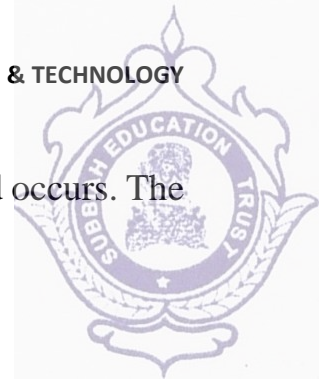

6. Loss of Head in Various Pipe Fittings

Pipe fittings in a piping system cause obstruction to flow and the loss of head occurs. The loss of head may be expressed as,

$$h = k \frac{v^2}{2g}$$

Where, K = Coefficient of pipe fitting

Various pipe fitting shown in following figure,

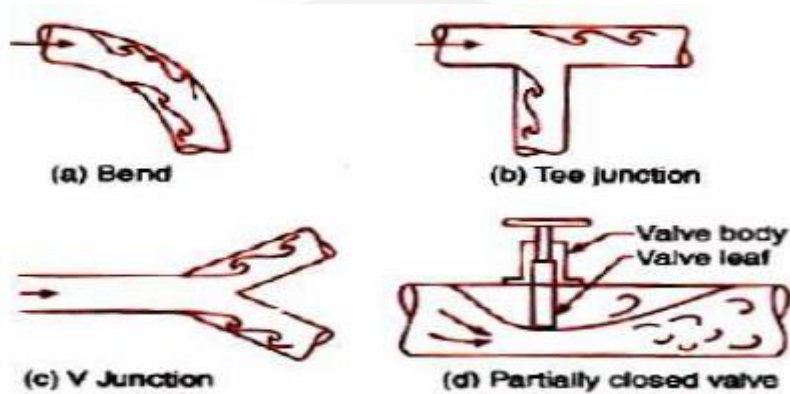

7. Loss of head due to obstruction

The loss of head due to obstruction in a pipe takes place due to reduction in the cross sectional area of the pipe by the presence of obstruction which is followed by an abrupt enlargement of the stream lines beyond the obstruction. (Shown in figure)

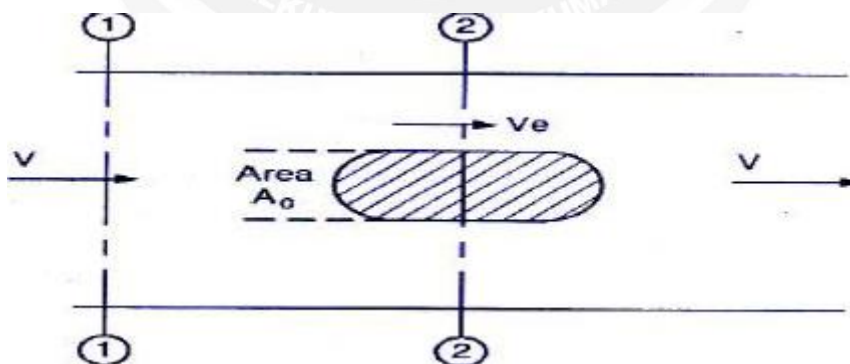

Let, V = Velocity of fluid in pipe

A₀ = Maximum area of obstruction

A = Area of pipe

h_o = head loss due to obstruction

$$h_o = \left[\frac{1}{C_c (A - A_o)} - 1 \right]^2 \frac{V^2}{2g}$$

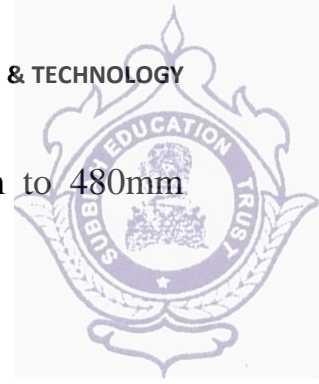

PROBLEM 1. At a sudden enlargement of a water main from 240mm to 480mm diameter, the hydraulic gradient rises by 10mm. Estimate the rate of flow.

Given: Dia. of smaller pipe $D_1 = 240\text{mm} = 0.24\text{m}$

$$\text{Area } A_1 = \frac{\pi D_1^2}{4} = \frac{\pi (0.24)^2}{4}$$

Dia. of larger pipe $D_2 = 480\text{mm} = 0.48\text{m}$

$$\text{Area } A_2 = \frac{\pi D_2^2}{4} = \frac{\pi (0.48)^2}{4}$$

$$\text{Rise of hydraulic gradient i.e. } Z_2 + \frac{P_2}{\rho g} - Z_1 + \frac{P_1}{\rho g} = 10\text{mm} = \frac{10}{1000}\text{m} = \frac{1}{100}\text{m}$$

Let the rate of flow = Q

Applying Bernoulli's equation to both sections i.e smaller and larger sections

$$\frac{P_1}{\rho g} + \frac{V_1^2}{2g} + Z_1 = \frac{P_2}{\rho g} + \frac{V_2^2}{2g} + Z_2 + \text{Head loss due to enlargement} \quad (1)$$

$$\text{But head loss due to enlargement, } h_e = \frac{V_1 - V_2^2}{2g} \quad (2)$$

From continuity equation, we have $A_1 V_1 = A_2 V_2$ $V_1 = \frac{A_2 V_2}{A_1}$

$$V_1 = \frac{\frac{\pi D_2^2 V_2}{4}}{\frac{\pi D_1^2}{4}} = \frac{D_2^2}{D_1^2} \times V_2 = \frac{0.48^2}{0.24^2} V_2 = 2^2 V_2 = 4V_2$$

Substituting this value in equation (2), we get

$$h_e = \frac{4V_2 - V_2^2}{2g} = \frac{3V_2^2}{2g} = \frac{9V_2^2}{2g}$$

Now substituting the value of h_e and V_1 in equation (1)

$$\frac{P_1}{\rho g} + \frac{4V_2^2}{2g} + Z_1 = \frac{P_2}{\rho g} + \frac{V_2^2}{2g} + Z_2 + \frac{9V_2^2}{2g}$$

$$\frac{16V_2^2}{2g} - \frac{V_2^2}{2g} - \frac{9V_2^2}{2g} = \frac{P_2}{\rho g} + Z_2 - \frac{P_1}{\rho g} + Z_1$$

$$\text{But Hydraulic gradient rise} = \frac{P_2}{\rho g} + Z_2 - \frac{P_1}{\rho g} + Z_1 = \frac{1}{100}\text{m}$$



$$\frac{6V_2^2}{2g} = \frac{1}{100} \text{ m} \quad V_2 = \frac{2 \times 9.81}{6 \times 100} = 0.1808 = 0.181 \text{ m/sec}$$

Discharge $Q = A_2 V_2 = \frac{\pi}{4} D_2^2 V_2$

$$= \frac{\pi}{4} (0.48)^2 \times 0.181 = 0.03275 \text{ m}^3/\text{sec}$$

$$= \underline{32.75 \text{ Lts/sec}}$$

PROBLEM 2. A 150mm dia. pipe reduces in dia. abruptly to 100mm dia. If the pipe carries water at 30lts/sec, calculate the pressure loss across the contraction. Take co-efficient of contraction as 0.6.

Given: Dia. of larger pipe $D_1 = 150\text{mm} = 0.15\text{m}$

Area of larger pipe $A_1 = \frac{\pi}{4} (0.15)^2 = 0.01767 \text{ m}^2$

Dia. of smaller pipe $D_2 = 100\text{mm} = 0.10\text{m}$

Area of smaller pipe $A_2 = \frac{\pi}{4} (0.10)^2 = 0.007854 \text{ m}^2$

Discharge $Q = 30 \text{ lts/sec} = 0.03 \text{ m}^3/\text{sec}$ Co-efficient of contraction $CC = 0.6$

From continuity equation, we have $Q = A_1 V_1 = A_2 V_2$

$$V_1 = \frac{Q}{A_1} = \frac{0.03}{0.01767} = 1.697 \text{ m/sec}$$

$$V_2 = \frac{Q}{A_2} = \frac{0.03}{0.007854} = 3.82 \text{ m/sec}$$

Applying Bernoulli's equation before and after contraction

$$\frac{P_1}{\rho g} + \frac{V_1^2}{2g} + Z_1 = \frac{P_2}{\rho g} + \frac{V_2^2}{2g} + Z_2 + h_c \quad (1)$$

But $Z_1 = Z_2$ and h_c the head loss due to contraction is given by the equation

$$h_c = \left(\frac{1}{C_c} - 1 \right)^2 \frac{v_2^2}{2g} = \frac{3.82^2}{2 \times 9.81} \left(\frac{1}{0.6} - 1 \right)^2 = 0.33$$

Substituting these values in equation (1), we get

$$\frac{P_1}{\rho g} + \frac{1.697^2}{2 \times 9.81} = \frac{P_2}{\rho g} + \frac{3.82^2}{2 \times 9.81} + 0.33$$



$$\frac{P_1}{\rho g} + 0.1467 = \frac{P_2}{\rho g} + 0.7438 + 0.33$$

$$\frac{P_1}{\rho g} - \frac{P_2}{\rho g} = 0.7438 + 0.33 - 0.1467 = 0.9271 \text{ m of Water}$$

$$P_1 - P_2 = \rho g \times 0.9271 = 1000 \times 9.81 \times 0.9271 = 0.909 \times 10^4 \text{ N/m}^2$$

$$= 0.909 \text{ N/cm}^2$$

Pressure loss across contraction = $P_1 - P_2 = 0.909 \text{ N/cm}^2$

PROBLEM 3. Water is flowing through a horizontal pipe of diameter 200mm at a velocity of 3m/sec. A circular solid plate of diameter 150mm is placed in the pipe to obstruct the flow. Find the loss of head due to obstruction in the pipe, if $C_c = 0.62$.

Given: Diameter of pipe $D = 200 \text{ mm} = 0.2 \text{ m}$

Velocity $V = 3 \text{ m/sec}$

$$\text{Area of pipe } A = \frac{\pi D^2}{4} = \frac{\pi (0.2)^2}{4} = 0.03141 \text{ m}^2$$

Diameter of obstruction $d = 150 \text{ mm} = 0.15 \text{ m}$

$$\text{Area of obstruction } a = \frac{\pi (0.15)^2}{4} = 0.01767 \text{ m}^2$$

$C_c = 0.62$

$$\text{The head loss due to obstruction } h_o = \left[\frac{1}{C_c (A - A_o)} - 1 \right]^2 \frac{V^2}{2g}$$

$$= \frac{9}{19.62} [3.687 - 1]^2$$

$$= 3.311 \text{ m}$$



4.4 MAJOR AND MINOR LOSSES OF FLOW IN PIPES

Major Losses

The major losses of energy are due to friction. Which are considerable hence it is called as major losses. It is determined by Darcy- Weisbach formula and Chezy's formula. Head loss due to friction is denoted by h_f .

Darcy- Weisbach formula

$$h_f = \frac{4 f L V^2}{2 g d}$$

Where, h_f – loss of head due to friction in meter of fluid

f - Coefficient of friction

Coefficient of friction is function of Reynolds's Number (Re).

If Re is less than 2000 (i.e. laminar flow) $f = \frac{16}{Re}$

If Re is greater than 4000 (i.e. turbulent flow) $f = \frac{0.0719}{Re^{1/4}}$ L- Length of pipe in m.

V- Velocity of flow in m/s.

d- Diameter of pipe in m.

Let, $V = \frac{Q}{A}$, Hence Darcy-Weisbach formula in the term of discharge Q,

$$h_f = \frac{f L Q^2}{12 d^5}$$

Chezy's formula-

$$V = C \sqrt{m i}$$

Where V – velocity of flow in m/s

C – Chezy's constant

i – Loss of head per unit length of pipe = $\frac{h_f}{L}$

m – Hydraulic mean depth = (Area of flow/ Perimeter) = A / P

$m = \frac{d}{4}$ for pipe flow

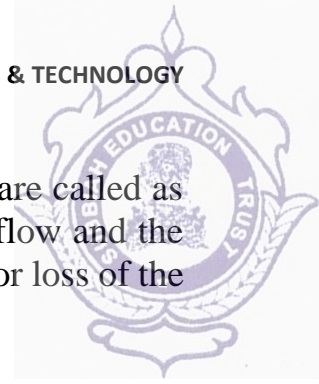

Minor losses

The losses due to disturbances in flow pattern or due to change in velocity are called as minor losses. These losses may occur due to sudden change in the area of flow and the direction of flow. These losses are less as compare to major losses. The minor loss of the head (energy) includes the following cases:

1. Loss of head due to sudden enlargement
2. Loss of head due to sudden contraction
3. Loss of head at the entrance of a pipe
4. Loss of head at the exit of a pipe
5. Loss of head due to bends
6. Loss of head in various pipe fittings
7. Loss of head due to obstruction

1. Loss of head due to sudden enlargement

Fig. represents a pipe in which fluid experiences sudden enlargement. Here the head loss occurs due to the separation of the flow at the periphery of the smaller pipe, which leads to eddying motion in the corner region.

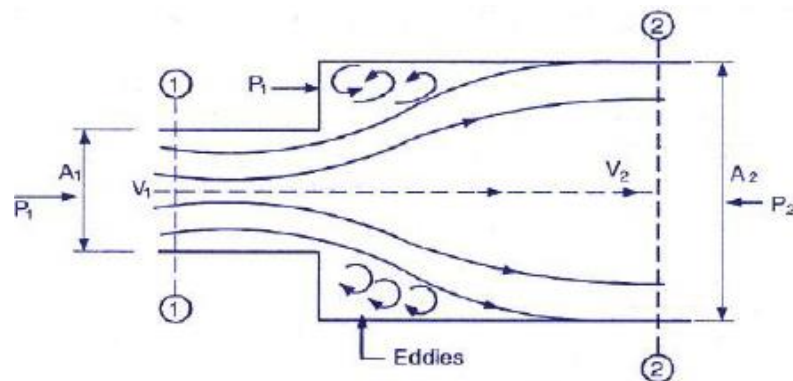

The Equation gives head loss due to sudden expansion.

$$h_e = \frac{(V_1 - V_2)^2}{2g}$$

Where, V_1 = Velocity of fluid at section 1-1

V_2 = Velocity of fluid at section 2-2

2. Loss of Head Due to Sudden Contraction

Fig. represents a pipe in which fluid experiences sudden contraction. The stream lines are converging from section 1-1 to section C-C. The head loss occurs only after the vena contracta CC. This is because the flow up to this section is accelerating and the boundary layer separation does not occur.

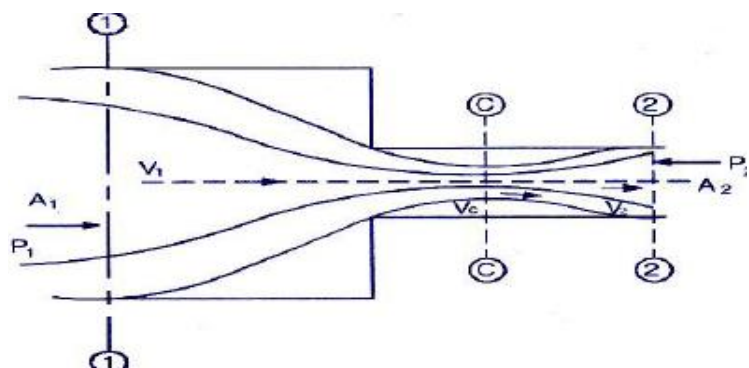



Using Bernoulli's equation, continuity and momentum equation at section 1-1 and 2-2, it can be proved that head loss due to sudden contraction is,

$$h_c = \left(\frac{1}{C_c} - 1 \right)^2 \frac{v_2^2}{2g}$$

Where, V_2 = Velocity of fluid at section 2-2

C_c = Coefficient of contraction = A_c / A_2

If C_c not given,

$$h_c = 0.5 \frac{v_2^2}{2g}$$

3. Loss of Head at the entrance of a pipe

The loss of head at the entrance of pipe is a similar case to loss of head due to sudden contraction as there is an abrupt reduction in area from an area of reservoir to area of a pipe. The loss of head is caused mainly by the turbulence created by the sudden enlargement of the jet after it has passed through the vena contracta.

$$h = 0.5 \frac{v^2}{2g}$$

4. Loss of head at the exit of a pipe

When the fluid from the pipe enters into a relatively larger reservoir the entire velocity is dissipated. If V is the velocity of fluid in a pipe, the head loss at exit is given by

$$h = \frac{v^2}{2g}$$

5. Loss of head due to bends

The loss of head in bends provided in pipes may be expressed as,

$$h = K \frac{v^2}{2g}$$

V is the mean velocity of flow of liquid and K = coefficient of bend and is depends on the angle of bend, radius of the curvature and diameter of pipe.

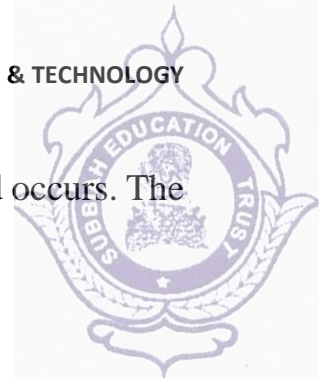

6. Loss of Head in Various Pipe Fittings

Pipe fittings in a piping system cause obstruction to flow and the loss of head occurs. The loss of head may be expressed as,

$$h = k \frac{v^2}{2g}$$

Where, K = Coefficient of pipe fitting

Various pipe fitting shown in following figure,

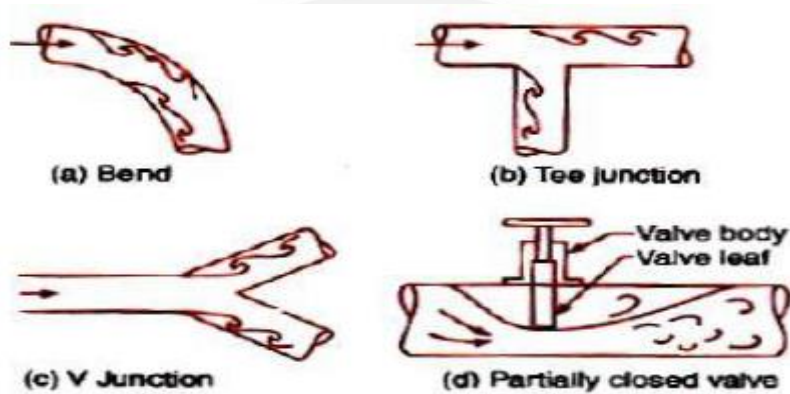

7. Loss of head due to obstruction

The loss of head due to obstruction in a pipe takes place due to reduction in the cross sectional area of the pipe by the presence of obstruction which is followed by an abrupt enlargement of the stream lines beyond the obstruction. (Shown in figure)

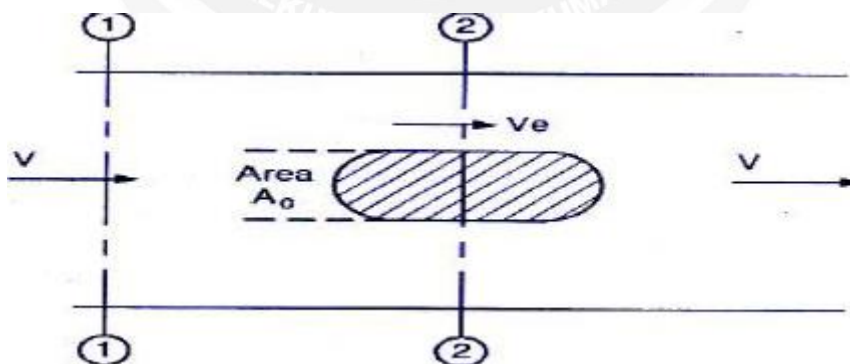

Let, V = Velocity of fluid in pipe

A0 = Maximum area of obstruction

A = Area of pipe

ho = head loss due to obstruction

$$h_o = \left[\frac{1}{C_c (A - A_o)} - 1 \right]^2 \frac{V^2}{2g}$$

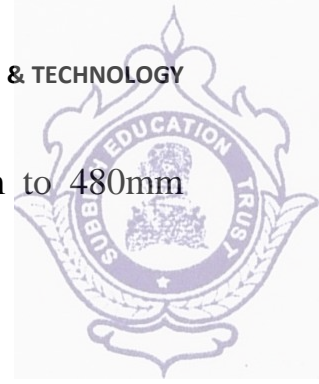

PROBLEM 1. At a sudden enlargement of a water main from 240mm to 480mm diameter, the hydraulic gradient rises by 10mm. Estimate the rate of flow.

Given: Dia. of smaller pipe $D_1 = 240\text{mm} = 0.24\text{m}$

$$\text{Area } A_1 = \frac{\pi D_1^2}{4} = \frac{\pi (0.24)^2}{4}$$

Dia. of larger pipe $D_2 = 480\text{mm} = 0.48\text{m}$

$$\text{Area } A_2 = \frac{\pi D_2^2}{4} = \frac{\pi (0.48)^2}{4}$$

$$\text{Rise of hydraulic gradient i.e. } Z_2 + \frac{P_2}{\rho g} - Z_1 + \frac{P_1}{\rho g} = 10\text{mm} = \frac{10}{1000}\text{m} = \frac{1}{100}\text{m}$$

Let the rate of flow = Q

Applying Bernoulli's equation to both sections i.e smaller and larger sections

$$\frac{P_1}{\rho g} + \frac{V_1^2}{2g} + Z_1 = \frac{P_2}{\rho g} + \frac{V_2^2}{2g} + Z_2 + \text{Head loss due to enlargement} \quad (1)$$

$$\text{But head loss due to enlargement, } h_e = \frac{V_1 - V_2^2}{2g} \quad (2)$$

From continuity equation, we have $A_1 V_1 = A_2 V_2$ $V_1 = \frac{A_2 V_2}{A_1}$

$$V_1 = \frac{\frac{\pi D_2^2 V_2}{4}}{\frac{\pi D_1^2}{4}} = \frac{D_2^2}{D_1^2} \times V_2 = \frac{0.48^2}{0.24^2} V_2 = 2^2 V_2 = 4V_2$$

Substituting this value in equation (2), we get

$$h_e = \frac{4V_2 - V_2^2}{2g} = \frac{3V_2^2}{2g} = \frac{9V_2^2}{2g}$$

Now substituting the value of h_e and V_1 in equation (1)

$$\frac{P_1}{\rho g} + \frac{4V_2^2}{2g} + Z_1 = \frac{P_2}{\rho g} + \frac{V_2^2}{2g} + Z_2 + \frac{9V_2^2}{2g}$$

$$\frac{16V_2^2}{2g} - \frac{V_2^2}{2g} - \frac{9V_2^2}{2g} = \frac{P_2}{\rho g} + Z_2 - \frac{P_1}{\rho g} + Z_1$$

$$\text{But Hydraulic gradient rise} = \frac{P_2}{\rho g} + Z_2 - \frac{P_1}{\rho g} + Z_1 = \frac{1}{100}\text{m}$$



$$\frac{6V_2^2}{2g} = \frac{1}{100} \text{ m} \quad V_2 = \frac{2 \times 9.81}{6 \times 100} = 0.1808 = 0.181 \text{ m/sec}$$

Discharge $Q = A_2 V_2 = \frac{\pi}{4} D_2^2 V_2$

$$= \frac{\pi}{4} (0.48)^2 \times 0.181 = 0.03275 \text{ m}^3/\text{sec}$$

$$= \underline{32.75 \text{ Lts/sec}}$$

PROBLEM 2. A 150mm dia. pipe reduces in dia. abruptly to 100mm dia. If the pipe carries water at 30lts/sec, calculate the pressure loss across the contraction. Take co-efficient of contraction as 0.6.

Given: Dia. of larger pipe $D_1 = 150\text{mm} = 0.15\text{m}$

Area of larger pipe $A_1 = \frac{\pi}{4} (0.15)^2 = 0.01767 \text{ m}^2$

Dia. of smaller pipe $D_2 = 100\text{mm} = 0.10\text{m}$

Area of smaller pipe $A_2 = \frac{\pi}{4} (0.10)^2 = 0.007854 \text{ m}^2$

Discharge $Q = 30 \text{ lts/sec} = 0.03 \text{ m}^3/\text{sec}$ Co-efficient of contraction $CC = 0.6$

From continuity equation, we have $Q = A_1 V_1 = A_2 V_2$

$$V_1 = \frac{Q}{A_1} = \frac{0.03}{0.01767} = 1.697 \text{ m/sec}$$

$$V_2 = \frac{Q}{A_2} = \frac{0.03}{0.007854} = 3.82 \text{ m/sec}$$

Applying Bernoulli's equation before and after contraction

$$\frac{P_1}{\rho g} + \frac{V_1^2}{2g} + Z_1 = \frac{P_2}{\rho g} + \frac{V_2^2}{2g} + Z_2 + h_c \quad (1)$$

But $Z_1 = Z_2$ and h_c the head loss due to contraction is given by the equation

$$h_c = \left(\frac{1}{C_c} - 1 \right)^2 \frac{v_2^2}{2g} = \frac{3.82^2}{2 \times 9.81} \left(\frac{1}{0.6} - 1 \right)^2 = 0.33$$

Substituting these values in equation (1), we get

$$\frac{P_1}{\rho g} + \frac{1.697^2}{2 \times 9.81} = \frac{P_2}{\rho g} + \frac{3.82^2}{2 \times 9.81} + 0.33$$



$$\frac{P_1}{\rho g} + 0.1467 = \frac{P_2}{\rho g} + 0.7438 + 0.33$$

$$\frac{P_1}{\rho g} - \frac{P_2}{\rho g} = 0.7438 + 0.33 - 0.1467 = 0.9271 \text{ m of Water}$$

$$P_1 - P_2 = \rho g \times 0.9271 = 1000 \times 9.81 \times 0.9271 = 0.909 \times 10^4 \text{ N/m}^2$$

$$= 0.909 \text{ N/cm}^2$$

Pressure loss across contraction = $P_1 - P_2 = 0.909 \text{ N/cm}^2$

PROBLEM 3. Water is flowing through a horizontal pipe of diameter 200mm at a velocity of 3m/sec. A circular solid plate of diameter 150mm is placed in the pipe to obstruct the flow. Find the loss of head due to obstruction in the pipe, if $C_c = 0.62$.

Given: Diameter of pipe $D = 200 \text{ mm} = 0.2 \text{ m}$

Velocity $V = 3 \text{ m/sec}$

$$\text{Area of pipe } A = \frac{\pi D^2}{4} = \frac{\pi (0.2)^2}{4} = 0.03141 \text{ m}^2$$

Diameter of obstruction $d = 150 \text{ mm} = 0.15 \text{ m}$

$$\text{Area of obstruction } a = \frac{\pi (0.15)^2}{4} = 0.01767 \text{ m}^2$$

$C_c = 0.62$

$$\text{The head loss due to obstruction } h_o = \left[\frac{1}{C_c (A - A_o)} - 1 \right]^2 \frac{V^2}{2g}$$

$$= \frac{9}{19.62} [3.687 - 1]^2$$

$$= 3.311 \text{ m}$$



5.1 BOUNDARY LAYER

When fluids flow over surfaces, the molecules near the surface are brought to rest due to the viscosity of the fluid. The adjacent layers are also slow down, but to a lower and lower extent. This slowing down is found limited to a thin layer near the surface. The fluid beyond this layer is not affected by the presence of the surface. The fluid layer near the surface in which there is a general slowing down is defined as boundary layer. The velocity of flow in this layer increases from zero at the surface to free stream velocity at the edge of the boundary layer.

When a real fluid flow past a solid body or a solid wall, the fluid particles adhere to the boundary and condition of no slip occurs. This means that the velocity of fluid close to the boundary will be same as that of the boundary. If the boundary is stationary, the velocity of fluid at the boundary will be zero. The theory dealing with boundary layer flows is called boundary layer theory.

According to the B.L. theory, the flow of fluid in the neighbourhood of the solid boundary may be divided into two regions as shown below

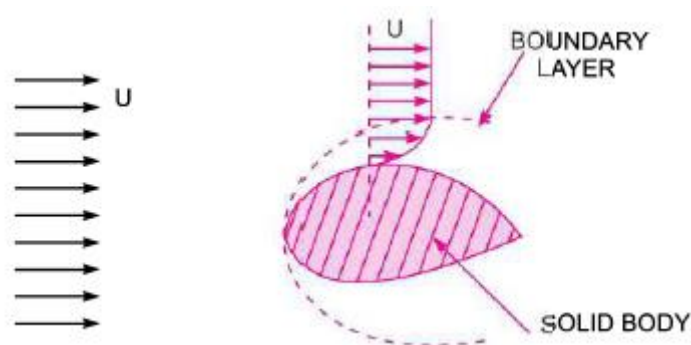

Figure 5.1.1 Description of the Boundary Layer

[Source: "Fluid Mechanics and Hydraulics Machines" by Dr.R.K.Bansal, Page: 611]

The simplest boundary layer to study is that formed in the flow along one side of a thin, smooth, flat plate parallel to the direction of the oncoming fluid. No other solid surface is near, and the pressure of the fluid is uniform. If the fluid were inviscid no velocity gradient would, in this instance, arise. The velocity gradients in a real fluid are therefore entirely due to viscous action near the surface.

The fluid, originally having velocity U_{∞} in the direction of plate, is retarded in the neighborhood of the surface, and the boundary layer begins at the leading edge of the plate. As more and more of the fluid is slowed down, the thickness of the layer increases. The fluid in contact with the plate surface has zero velocity, 'no slip' and a velocity gradient exists between the fluid in the free stream and the plate surface.

The flow in the first part of the boundary layer (close to the leading edge of the plate) is entirely laminar. With increasing thickness, however, the laminar layer becomes unstable, and the motion within it becomes disturbed. The irregularities of the flow develop into turbulence, and the thickness of the layer increases more rapidly. The changes from laminar to turbulent flow take place over a short length known as the transition region.

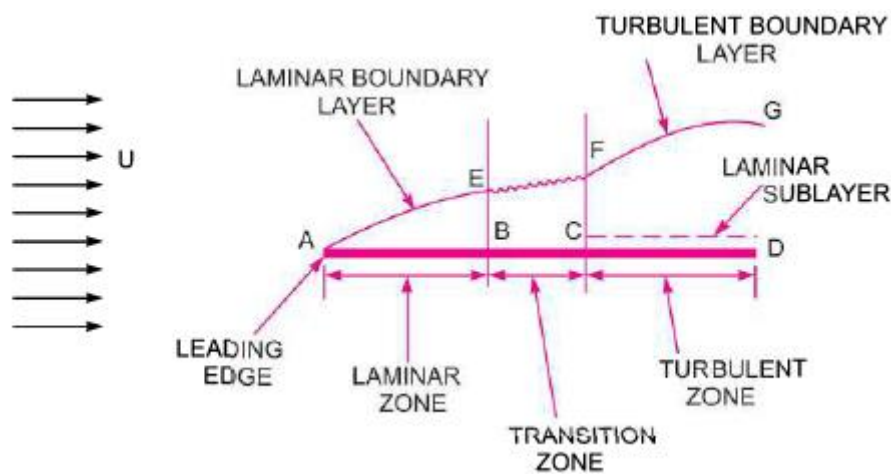

Graph of velocity u against distance y from surface at point X

Reynolds' Number Concept

If the Reynolds number locally were based on the distance from the leading edge of the plate, then it will be appreciated that, initially, the value is low, so that the fluid flow close to the wall may be categorized as laminar. However, as the distance from the leading edge increases, so does the Reynolds number until a point is reached where the flow regime becomes turbulent.

For smooth, polished plates the transition may be delayed until Re equals 500000. However, for rough plates or for turbulent approach flows transition may occur at much lower values. Again, the transition does not occur in practice at one well-defined point but, rather, a transition zone is established between the two flow regimes.

The figure above also depicts the distribution of shear stress along the plate in the flow direction. At the leading edge, the velocity gradient is large, resulting in a high shear stress. However, as the laminar region progresses, so the velocity gradient and shear stress decrease with thickening of the boundary layer. Following transition the velocity gradient again increases and the shear stress rises.

Theoretically, for an infinite plate, the boundary layer goes on thickening indefinitely. However, in practice, the growth is curtailed by other surfaces in the vicinity.

Factors affecting transition from Laminar to Turbulent flow Regimes

As mentioned earlier, the transition from laminar to turbulent boundary layer condition may be considered as Reynolds number dependent,

$$Re_x = \frac{\rho U_s x}{\mu} = \frac{\rho x}{\nu} \quad \text{and a figure of } 5 \times 10^5 \text{ is often quoted.}$$

However, this figure may be considerably reduced if the surface is rough. For $Re < 10^5$, the laminar layer is stable; however, at Re near 2×10^5 it is difficult to prevent transition.



5.2 BOUNDARY LAYER THICKNESS

Boundary Layer thickness (δ)

The velocity within the boundary layer increases from zero at the boundary surface to the velocity of the main stream asymptotically. Therefore the thickness of the boundary layer is arbitrarily defined as that distance from the boundary in which the velocity reaches 99 per cent of the velocity of the free stream ($u = 0.99U_\infty$). It is denoted by the symbol (δ). This definition however gives an approximate value of the boundary layer thickness and hence δ is generally termed as nominal thickness of the boundary layer.

The boundary layer thickness for greater accuracy is defined as in terms of certain mathematical expression which are the measure of the boundary layer on the flow. The commonly adopted definitions of the boundary layer thickness are:

1. Displacement thickness (δ^*)
2. Momentum thickness (θ)
3. Energy thickness (δ_e)

Displacement thickness (δ^*)

The displacement thickness can be defined as the distance measured perpendicular to the boundary by which the main/free stream is displaced on account of formation boundary layer.

or

It is an additional “Wall thickness” that would have to be added to compensate for the reduction in flow rate on account of boundary layer formation”.

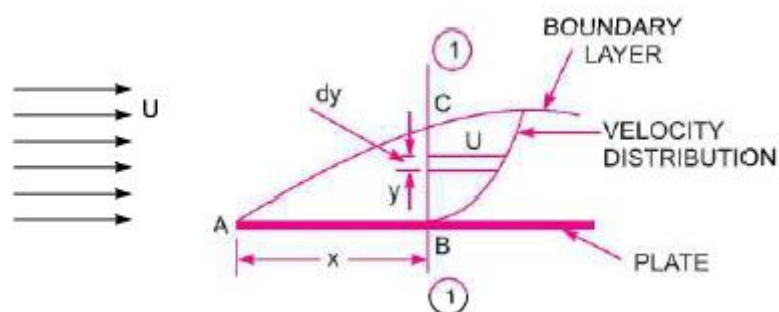

Figure 5.2.1 Displacement thickness

[Source: “Fluid Mechanics and Hydraulics Machines” by Dr.R.K.Bansal, Page: 613]

Let fluid of density ρ flow past a stationary plate with velocity U as shown above. Consider an elementary strip of thickness dy at a distance y from the plate.



Assumed unit width, the mass flow per second through the elementary strip

$$= \rho u dy \text{ ----- (i)}$$

Mass of flow per second through the elementary strip (unit width) if the plate were not there

$$= \rho U dy \text{ ----- (ii)}$$

Reduce the mass flow rate through the elementary strip

$$\begin{aligned} &= \rho U dy - \rho u dy \\ &= \rho (U - u) dy \end{aligned}$$

Total momentum of mass flow rate due to introduction of plate

$$= \int_0^{\delta} \rho (U - u) dy \text{ ----- (iii)}$$

(If the fluid is incompressible)

Let the plate is displaced by a distance (δ^*) and velocity of flow for the distance (δ^*) is equal to the main/free stream velocity (i.e. U). Then, loss of the mass of the fluid/sec. flowing through the distance (δ^*) .

$$= \rho U \sigma^* \text{ ----- (iv)}$$

Equating eqns. (iii) and (iv) we get

$$= \rho U \sigma^* = \int_0^{\sigma} \rho (U - u) dy$$

or

$$\sigma^* = \int_0^{\sigma} \left(1 - \frac{u}{U} \right) dy$$

Momentum Thickness (θ)

This is defined as the distance which the total loss of momentum per second be equal to if it were passing a stationary plate. It is denoted by θ .

It may also be defined as the distance, measured perpendicular to the boundary of the solid body by which the boundary should be displaced to compensate for reduction in momentum of the flowing fluid on account of boundary layer formation.

Refer to diagram of displacement thickness above,

Mass of flow per second through the elementary strip = $\rho u dy$

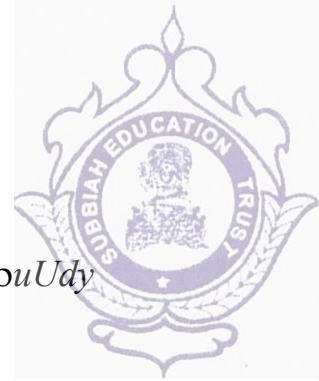

Momentum/Sec. of this fluid inside the boundary layer

$$= \rho u dy \times U = \rho u^2 dy$$

Momentum/sec. of the same mass of fluid before entering boundary layer = $\rho u U dy$

Loss of Momentum/sec. = $\rho u U dy - \rho u^2 dy = \rho u (U - u) dy$

∴ Total loss of momentum/sec

$$= \int_0^\delta \rho u (U - u) dy \text{ ----- (i)}$$

Let θ = Distance by which plate is displaced when the fluid is flowing with a constant velocity U . then loss of momentum/Sec. of fluid flowing through distance θ with a velocity U .

$$= \rho \theta U^2 \text{ ----- (ii)}$$

Equating eqns. (i) and (ii), we have

$$\rho \theta U^2 = \int_0^\delta \rho u (U - u) dy$$

OR

$$\theta = \int_0^\delta \frac{u}{U} \left(1 - \frac{u}{U} \right) dy$$

Energy Thickness (δ^{**})

Energy thickness is defined as the distance measured perpendicular to the boundary of the solid body, by which the boundary should be displaced to compensate for the reduction in K.E of the flowing fluid on account of boundary layer formation. It is denoted by (δ^{**})

Refer to the above displacement thickness diagram,

Mass of flow per second through the elementary strip = $\rho u dy$

K.E of this fluid inside the boundary layer

$$= \frac{1}{2} m u^2 = \frac{1}{2} (\rho u dy) u^2$$

K.E of the same mass of fluid before entering the boundary layer

$$\frac{1}{2} (\rho u dy) u^2$$



Loss of K.E. through elementary strip

$$\begin{aligned} & \frac{1}{2}(\rho u dy)u^2 - \frac{1}{2}(\rho u dy)u^2 \\ & = \frac{1}{2}\rho u(U^2 - u^2)dy \text{ ----- (i)} \end{aligned}$$

∴ Total loss of K.E of fluid

$$= \int_0^\delta \frac{1}{2}\rho u(U^2 - u^2)dy$$

Let (δ^{**}) = Distance by which the plate is displaced to compensate for the reduction in K.E

Then loss of K.E. through (δ^{**}) of fluid flowing with velocity

$$U = \frac{1}{2}(\rho U \delta_e)U^2 \text{ ----- (ii)}$$

Equating eqns (i) and (ii), we have

$$\frac{1}{2}(\rho u dy)u^2 = \int_0^\delta \frac{1}{2}\rho u(U^2 - u^2)dy$$

$$\delta_e = \frac{1}{U^3} \int_0^\delta u(U^2 - u^2)dy$$

or

$$\int_0^\delta \frac{u}{U} \left(1 - \frac{u^2}{U^2}\right) dy$$



5.3 DRAG FORCE ON FLAT PLATE DUE TO BOUNDARY LAYER

Momentum Equation for Boundary Layer by Von Karman

Von Karman suggested a method based on the momentum equation by the use of which the growth of a boundary layer along a flat plate, the wall shear stress and the drag force could be determined (when the velocity distribution in the boundary layer is known). Starting from the beginning of the plate, the method can be used for both laminar and turbulent boundary layers.

The figure below shows a fluid flowing over a thin plate (placed at zero incidence) with a free stream velocity equal to U . Consider a small length dx of the plate at a distance x from the leading edge as shown in fig. (a). Consider unit width of plate perpendicular to the direction of flow.

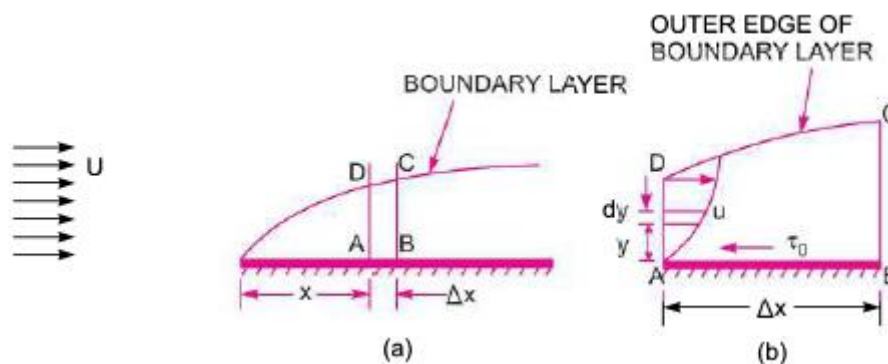

Figure 5.3.1 Drag Force on Flat Plate due to Boundary layer

[Source: "Fluid Mechanics and Hydraulics Machines" by Dr.R.K.Bansal, Page: 619]

Let ABCD be a small element of a boundary layer (the edge DC represents the outer edge of the boundary layer).

Mass rate of fluid entering through AD

$$= \int_0^{\delta} \rho u dy + \frac{d}{dx} \left[\int_0^{\delta} \rho u dy \right] dx \text{ ----- (ii) } \left[\begin{array}{l} \text{i.e. (mass through AD) + } \frac{d}{dx} \\ \text{(mass through AD) } \times dx \end{array} \right]$$

∴ Mass rate of fluid entering the control volume through the surface DC

= mass rate of fluid through BC – Mass rate of fluid through AD

$$= \int_0^{\delta} \rho u dy + \frac{d}{dx} \left[\int_0^{\delta} \rho u dy \right] dx - \int_0^{\delta} \rho u dy \text{ ----- (iii)}$$

$$= \frac{d}{dx} \left[\int_0^{\delta} \rho u dy \right] dx \text{ ----- (iv)}$$

The fluid is entering through DC with a uniform velocity U .

Momentum rate of fluid entering the control volume of X-direction through AD.

$$\int_0^{\delta} \rho u^2 dy \text{ ----- (v)}$$

Momentum rate of fluid leaving the Control Volume in X-direction through BC



$$= \int_0^\delta \rho u^2 dy + \frac{d}{dx} \left[\int_0^\delta \rho u^2 dy \right] dx \text{ -----(vi)}$$

Momentum rate of fluid entering the control volume through DC in X-direction

$$= \frac{d}{dx} \left[\int_0^\delta \rho u dy \right] dx \times U \quad (\because \text{Velocity} = U) \text{ -----(vii)}$$

$$= \frac{d}{dx} \left[\int_0^\delta \rho u U dy \right] dx \text{ -----(viii)}$$

∴ Rate of change of momentum of Control Volume = Momentum rate of fluid through BC – Momentum rate of fluid through AD – Momentum of fluid through DC

$$= \int_0^\delta \rho u^2 dy + \frac{d}{dx} \left[\int_0^\delta \rho u^2 dy \right] dx - \int_0^\delta \rho u^2 dy + \frac{d}{dx} \left[\int_0^\delta \rho u U dy \right] dx \text{ -----(ix)}$$

$$= \frac{d}{dx} \left[\int_0^\delta \rho u^2 dy - \int_0^\delta \rho u U dy \right] dx \text{ -----}$$

$$= \frac{d}{dx} \left[\int_0^\delta (\rho u^2 dy - \rho u U dy) \right] dx$$

$$= \frac{d}{dx} \left[\rho \int_0^\delta (u^2 - uU) dy \right] dx \text{ -----(x)}$$

As per momentum principle, the rate of change of momentum on the control volume BCD must be equal to the total force on the control volume in the same direction. The only external force acting on the control volume is the shear force acting on the side AB in the direction B to A (fig. b) above). The value of this force (drag force) is given by,

$$\Delta F_D = \tau_o \times dx$$

Thus the total external force in the direction of the rate of change of momentum

$$= - \tau_o \times dx \text{ -----(xi)}$$

Equating equation (x) and (xi), we have

$$- \tau_o \times dx = \rho \frac{d}{dx} \left[\int_0^\delta (u^2 - uU) dy \right] dx$$

or

$$\rho \frac{d}{dx} \left[\int_0^\delta (u^2 - uU) dy \right]$$

$$\text{or,} = \rho \frac{d}{dx} \left[\int_0^\delta (uU - u^2) dy \right]$$

$$= \rho \frac{d}{dx} \left[\int_0^\delta U^2 \left(\frac{u}{U} - \frac{u^2}{U^2} \right) dy \right]$$

$$= \rho U \frac{d}{dx} \left[\int_0^\delta \frac{u}{U} \left[1 - \frac{u}{U} \right] dy \right]$$

$$\text{or} \frac{\tau_o}{\rho U^2} = \frac{d}{dx} \left[\int_0^\delta \frac{u}{U} \left(1 - \frac{u}{U} \right) dy \right] \text{ -----(xiii)}$$



But,

$$\int_0^{\delta} \frac{u}{U} \left(1 - \frac{u}{U}\right) dy = \text{momentum thickness } \theta$$

$$\therefore \frac{\tau_o}{\rho U^2} = \frac{d\theta}{dx} \text{-----(xvii)}$$

This equation is known as von Karman momentum equation for boundary layer flow and it is used to find out the frictional drag on smooth flat plate for both laminar and turbulent boundary layer.

The following boundary conditions must be satisfied for any assumed velocity distribution.

- (i) At the surface of the plate $y = 0, U = 0, \frac{du}{dy} = \text{finite value}$
- (ii) At the outer edge of boundary layer $y = \delta, u = U, \frac{du}{dy} = 0$

The shear stress, τ_o for a given velocity profile in laminar, transition or turbulent zone is obtained from equations (xii) and (xiii) above. Then drag force on a small distance dx of a plate is given by

$$\Delta F_D = \text{shear stress} \times \text{area}$$

$$= \tau_o \times (B \times dx) = \tau_o \times B \times dx \text{ [assuming width of plate as unity]}$$

where, $B = \text{width of the plate}$

\therefore Total drag on the plate of length L one side,

$$F_D = \int \Delta F_D = \int_0^L \tau_o \times B \times dx$$

- The ratio of the shear stress to the quantity $\frac{1}{2} \rho u^2$ is known as the Local coefficient of drag” (or co-efficient of skin fraction) and is denoted by C_D^* i.e.

$$C_D^* = \frac{\tau_o}{\frac{1}{2} \rho u^2}$$

- The ratio of the total drag force to the quantity $\frac{1}{2} \rho U^2$ is called ‘Average-coefficient of drag’ and is denoted by C_D i.e. $C_D = \frac{F_D}{\frac{1}{2} \rho A U^2}$

ρ = Mass density of fluid

A = Area of surface/plate, and

U = free stream velocity



5.4 Solved Problems Boundary Layer Thickness

PROBLEM 1: The velocity distribution in the boundary layer is given by

$$\frac{u}{U} = \frac{y}{\delta}$$

where u is the velocity y from the plate and $u=U$ at $y=\delta$, δ being boundary layer thickness. Find

- i. The displacement thickness
- ii. The momentum thickness
- iii. The energy thickness and
- iv. The value of δ^* / θ .

Solution:

Velocity distribution:

$$\frac{u}{U} = \frac{y}{\delta}$$

(i) The displacement thickness δ^*

$$\begin{aligned} \delta^* &= \int_0^{\delta} \left(1 - \frac{u}{U}\right) dy \\ &= \int_0^{\delta} \left(1 - \frac{y}{\delta}\right) dy \\ &= \left[y - \frac{y^2}{2\delta} \right]_0^{\delta} \\ &= \left(\delta - \frac{\delta^2}{2\delta} \right) = \delta - \frac{\delta}{2} \\ &= \frac{\delta}{2} \end{aligned}$$

(ii) The momentum thickness

$$\begin{aligned} \theta &= \int_0^{\delta} \frac{u}{U} \left(1 - \frac{u}{U}\right) dy \\ &= \int_0^{\delta} \frac{y}{\delta} \left(1 - \frac{y}{\delta}\right) dy \\ &= \int_0^{\delta} \left(\frac{y}{\delta} - \frac{y^2}{\delta^2} \right) dy \end{aligned}$$



or

$$\theta = \left[\frac{y^2}{2\delta} - \frac{y^3}{3\delta^2} \right]_0^\sigma = \frac{\delta^2}{2\delta} - \frac{\delta^3}{3\delta^2} = \frac{\delta}{2} - \frac{\delta}{3} = \frac{\delta}{6}$$

iii. The energy thickness

$$\begin{aligned} \delta_e &= \int_0^\delta \frac{u}{U} \left(1 - \frac{u^2}{U^2} \right) dy \\ &= \int_0^\delta \frac{y}{\delta} \left(1 - \frac{y^2}{\delta^2} \right) dy = \int_0^\delta \left(\frac{y}{\delta} - \frac{y^3}{\delta^3} \right) dy \\ &= \left[\frac{y^2}{2\delta} - \frac{y^4}{4\delta^3} \right]_0^\delta = \frac{\delta^2}{2\delta} - \frac{\delta^4}{4\delta^3} \\ &= \frac{\delta}{2} - \frac{\delta}{4} \\ &= \frac{\delta}{4} \end{aligned}$$

iv. The value of δ^*/θ .

$$\begin{aligned} \frac{\delta^*}{\theta} &= \frac{\delta/2}{\delta/6} \\ &= 3.0 \end{aligned}$$

PROBLEM 2: The velocity distribution in the boundary layer is given by ,

$$\frac{u}{U} = \frac{3}{2} \frac{y}{\sigma} - \frac{1}{2} \frac{y^2}{\sigma^2}$$

σ being the boundary layer thickness. Calculate the following

- (i) The ratio of displacement thickness to boundary layer thickness $\left(\frac{\delta^*}{\delta} \right)$
- (ii) The ratio of momentum thickness to boundary layer thickness $\left(\frac{\theta}{\delta} \right)$

Solution

Velocity distribution: $\frac{u}{U} = \frac{3}{2} \frac{y}{\sigma} - \frac{1}{2} \frac{y^2}{\sigma^2}$



$$(i) \quad \frac{\delta^*}{\delta}:$$

$$\delta^* = \int_0^\delta \left(1 - \frac{u}{U}\right) dy = \int_0^\delta \left(1 - \frac{3}{2} \frac{y}{\sigma} + \frac{1}{2} \frac{y^2}{\sigma^2}\right) dy$$

$$= \left[y - \frac{3}{2} \times \frac{y^2}{2\sigma} + \frac{1}{2} \times \frac{y^3}{3\sigma^2} \right]_0^\delta$$

$$\left[\sigma - \frac{3}{4} \frac{\sigma^2}{\sigma} + \frac{1}{2} \frac{\sigma^2}{3\sigma^2} \right]$$

$$= \left(\sigma - \frac{3}{4} \sigma + \frac{\sigma}{6} \right)$$

$$\sigma^* = \frac{5}{12} \sigma$$

$$\therefore \frac{\sigma^*}{\sigma} = \frac{5}{12}$$

$$(ii) \quad \theta/\sigma$$

$$\theta = \int_0^\sigma \frac{u}{U} \left(1 - \frac{u}{U}\right) dy$$

$$= \int_0^\sigma \left(\frac{3}{2} \frac{y}{\sigma} - \frac{1}{2} \frac{y^2}{\sigma^2} \right) \left(1 - \frac{3}{2} \frac{y}{\sigma} + \frac{1}{2} \frac{y^2}{\sigma^2} \right) dy$$

$$= \int_0^\sigma \left(\frac{3}{2} \frac{y}{\sigma} - \frac{9}{4} \frac{y^2}{\sigma^2} + \frac{3}{4} \frac{y^3}{\sigma^3} - \frac{1}{2} \frac{y^2}{\sigma^2} + \frac{3}{4} \frac{y^3}{\sigma^3} - \frac{1}{4} \frac{y^4}{\sigma^4} \right) dy$$

$$= \int_0^\sigma \left[\frac{3}{2} \frac{y}{\sigma} - \left(\frac{9}{4} \frac{y^2}{\sigma^2} + \frac{1}{2} \frac{y^2}{\sigma^2} \right) + \left(\frac{3}{4} \frac{y^3}{\sigma^3} + \frac{3}{4} \frac{y^3}{\sigma^3} \right) - \frac{1}{4} \frac{y^4}{\sigma^4} \right] dy$$

$$= \int_0^\sigma \left(\frac{3}{2} \frac{y}{\sigma} - \frac{11}{4} \frac{y^2}{\sigma^2} + \frac{3}{2} \frac{y^3}{\sigma^3} - \frac{1}{4} \frac{y^4}{\sigma^4} \right) dy$$

$$= \left[\frac{3}{2} \frac{y^2}{2\sigma} - \frac{11}{4} \frac{y^3}{3\sigma^2} + \frac{3}{2} \times \frac{y^4}{4\sigma^3} - \frac{1}{4} \times \frac{y^5}{4\sigma^4} \right]_0^\delta$$



$$= \left[\frac{3}{2} \times \frac{y^2}{2\sigma} \times \frac{11}{4} \times \frac{y^3}{3\sigma^2} + \frac{3}{2} \times \frac{\sigma^4}{4\sigma^3} - \frac{1}{4} \times \frac{\sigma^5}{5\sigma^4} \right]_0^\delta$$

$$\theta = \left(\frac{3}{4}\sigma - \frac{11}{12}\sigma + \frac{3}{8}\sigma - \frac{1}{20}\sigma \right) = \frac{19}{120}\sigma$$

PROBLEM 3 : Find the displacement thickness, the momentum thickness and energy thickness for the velocity distribution in the boundary layer is given by

$$\frac{u}{U} = 2 \left(\frac{y}{\delta} \right) - \left(\frac{y}{\delta} \right)^2.$$

Solution. Given :

Velocity distribution $\frac{u}{U} = 2 \left(\frac{y}{\delta} \right) - \left(\frac{y}{\delta} \right)^2$

(i) Displacement thickness δ^* is given by equation

$$\delta^* = \int_0^\delta \left(1 - \frac{u}{U} \right) dy$$

Substituting the value of $\frac{u}{U} = 2 \left(\frac{y}{\delta} \right) - \left(\frac{y}{\delta} \right)^2$, we have

$$\begin{aligned} \delta^* &= \int_0^\delta \left\{ 1 - \left[2 \left(\frac{y}{\delta} \right) - \left(\frac{y}{\delta} \right)^2 \right] \right\} dy \\ &= \int_0^\delta \left\{ 1 - 2 \left(\frac{y}{\delta} \right) + \left(\frac{y}{\delta} \right)^2 \right\} dy = \left[y - \frac{2y^2}{2\delta} + \frac{y^3}{3\delta^2} \right]_0^\delta \\ &= \delta - \frac{\delta^2}{\delta} + \frac{\delta^3}{3\delta^2} = \delta - \delta + \frac{\delta}{3} = \frac{\delta}{3}. \quad \text{Ans.} \end{aligned}$$

(ii) Momentum thickness θ , is given by equation

$$\begin{aligned} \theta &= \int_0^\delta \frac{u}{U} \left\{ 1 - \frac{u}{U} \right\} dy = \int_0^\delta \left(\frac{2y}{\delta} - \frac{y^2}{\delta^2} \right) \left[1 - \left(\frac{2y}{\delta} - \frac{y^2}{\delta^2} \right) \right] dy \\ &= \int_0^\delta \left[\frac{2y}{\delta} - \frac{y^2}{\delta^2} \right] \left[1 - \frac{2y}{\delta} + \frac{y^2}{\delta^2} \right] dy \\ &= \int_0^\delta \left[\frac{2y}{\delta} - \frac{4y^2}{\delta^2} + \frac{2y^3}{\delta^3} - \frac{y^2}{\delta^2} + \frac{2y^3}{\delta^3} - \frac{y^4}{\delta^4} \right] dy \\ &= \int_0^\delta \left[\frac{2y}{\delta} - \frac{5y^2}{\delta^2} + \frac{4y^3}{\delta^3} - \frac{y^4}{\delta^4} \right] dy = \left[\frac{2y^2}{2\delta} - \frac{5y^3}{3\delta^2} + \frac{4y^4}{4\delta^3} - \frac{y^5}{5\delta^4} \right]_0^\delta \end{aligned}$$



$$= \left[\frac{\delta^2}{\delta} - \frac{5\delta^3}{3\delta^2} + \frac{\delta^4}{\delta^3} - \frac{\delta^5}{5\delta^4} \right] = \delta - \frac{5\delta}{3} + \delta - \frac{\delta}{5}$$

$$= \frac{15\delta - 25\delta + 15\delta - 3\delta}{15} = \frac{30\delta - 28\delta}{15} = \frac{2\delta}{15} \quad \text{Ans.}$$

(iii) Energy thickness δ^{**} is given by equation

$$\delta^{**} = \int_0^\delta \frac{u}{U} \left[1 - \frac{u^2}{U^2} \right] dy = \int_0^\delta \left(\frac{2y}{\delta} - \frac{y^2}{\delta^2} \right) \left(1 - \left[\frac{2y}{\delta} - \frac{y^2}{\delta^2} \right]^2 \right) dy$$

$$= \int_0^\delta \left(\frac{2y}{\delta} - \frac{y^2}{\delta^2} \right) \left(1 - \left[\frac{4y^2}{\delta^2} + \frac{y^4}{\delta^4} - \frac{4y^3}{\delta^3} \right] \right) dy$$

$$= \int_0^\delta \left(\frac{2y}{\delta} - \frac{y^2}{\delta^2} \right) \left(1 - \frac{4y^2}{\delta^2} - \frac{y^4}{\delta^4} + \frac{4y^3}{\delta^3} \right) dy$$

$$= \int_0^\delta \left(\frac{2y}{\delta} - \frac{y^2}{\delta^2} \right) \left(1 - \frac{4y^2}{\delta^2} - \frac{y^4}{\delta^4} + \frac{4y^3}{\delta^3} \right) dy$$

$$= \int_0^\delta \left(\frac{2y}{\delta} - \frac{8y^3}{\delta^3} - \frac{2y^5}{\delta^5} + \frac{8y^4}{\delta^4} - \frac{y^2}{\delta^2} + \frac{4y^4}{\delta^4} + \frac{y^6}{\delta^6} - \frac{4y^5}{\delta^5} \right) dy$$

$$= \int_0^\delta \left[\frac{2y}{\delta} - \frac{y^2}{\delta^2} - \frac{8y^3}{\delta^3} + \frac{12y^4}{\delta^4} - \frac{6y^5}{\delta^5} + \frac{y^6}{\delta^6} \right] dy$$

$$= \left[\frac{2y^2}{2\delta} - \frac{y^3}{3\delta^2} - \frac{8y^4}{4\delta^3} + \frac{12y^5}{5\delta^4} - \frac{6y^6}{6\delta^5} + \frac{y^7}{7\delta^6} \right]_0^\delta$$

$$= \frac{\delta^2}{\delta} - \frac{\delta^3}{3\delta^2} - \frac{2\delta^4}{\delta^3} + \frac{12\delta^5}{5\delta^4} - \frac{\delta^6}{\delta^5} + \frac{\delta^7}{7\delta^6} = \delta - \frac{\delta}{3} - 2\delta + \frac{12}{5}\delta - \delta + \frac{\delta}{7}$$

$$= -2\delta - \frac{\delta}{3} + \frac{12}{5}\delta + \frac{\delta}{7} = \frac{-210\delta - 35\delta + 252\delta + 15\delta}{105}$$

$$= \frac{-245\delta + 267\delta}{105} = \frac{22\delta}{105} \quad \text{Ans.}$$

PROBLEM 4: For the velocity for the laminar boundary layer flows given as

$$\frac{u}{U} = 2 \left(\frac{y}{\delta} \right) - \left(\frac{y}{\delta} \right)^2$$

find out the expression for boundary layer thickness (δ), shear stress (τ_0), co-efficient of drag (C_D) in terms of Reynolds number.

Solution. Given :

(i) The velocity distribution $\frac{u}{U} = 2 \left(\frac{y}{\delta} \right) - \left(\frac{y}{\delta} \right)^2 \quad \dots(i)$



Substituting this value of $\frac{u}{U}$, we get

$$\begin{aligned} \frac{\tau_o}{\rho U^2} &= \frac{d}{dx} \left[\int_0^\sigma \left(\frac{2y}{\sigma} - \frac{y^2}{\sigma^2} \right) \left(1 - \left(\frac{2y}{\sigma} - \frac{y^2}{\sigma^2} \right) \right) dy \right] \\ &= \frac{d}{dx} \left[\int_0^\sigma \left(\frac{2y}{\sigma} - \frac{y^2}{\sigma^2} \right) \left(1 - \frac{2y}{\sigma} + \frac{y^2}{\sigma^2} \right) dy \right] \\ &= \frac{d}{dx} \left[\int_0^\sigma \left(\frac{2y}{\sigma} - \frac{4y^2}{\sigma^2} + \frac{2y^3}{\sigma^3} - \frac{y^2}{\sigma^2} + \frac{2y^3}{\sigma^3} - \frac{y^4}{\sigma^2} \right) dy \right] \\ &= \frac{d}{dx} \left[\int_0^\sigma \left(\frac{2y}{\sigma} - \frac{5y^2}{\sigma^2} + \frac{4y^3}{\sigma^3} - \frac{y^4}{\sigma^4} \right) dy \right] \\ &= \frac{d}{dx} \left[\frac{2}{2} \frac{y^2}{\sigma} - \frac{5}{3} \frac{y^2}{\sigma^2} + \frac{4}{4} \frac{y^4}{\sigma^3} - \frac{1}{5} \frac{y^5}{\sigma^4} \right]_0^\sigma \\ &= \frac{d}{dx} \left[\sigma - \frac{5}{3} \sigma + \sigma \frac{1}{5} \sigma \right] = \frac{d}{dx} \left(\frac{2}{15} \sigma \right) \\ \therefore \tau_o &= \rho U^2 \times \frac{d}{dx} \left(\frac{2}{15} \sigma \right) = \frac{2}{15} \rho U^2 \frac{d\delta}{dx} \text{-----(ii)} \end{aligned}$$

Also, according to Newton's law of viscosity

$$\tau_o = \mu \left(\frac{dy}{dx} \right)_{y=0} \text{-----(iii)}$$

But $u = U \left(\frac{2y}{\sigma} - \frac{y^2}{\sigma^2} \right)$

But $u = U \left(\frac{2y}{\sigma} - \frac{y^2}{\sigma^2} \right)$

and $\frac{du}{dx} = U \left(\frac{2}{\sigma} - \frac{2y}{\sigma^2} \right)$, U being constant

$$\therefore \left(\frac{du}{dx} \right)_{y=0} = U \left(\frac{2}{\sigma} - 0 \right) = \frac{2U}{\sigma}$$

Substituting this value in (iii), we get

$$\tau_o = \frac{2\mu U}{\sigma} \text{-----(iv)}$$

Equating the values of τ_o given by equations (ii) and iv, we get



$$\frac{2}{15} \rho U^2 \frac{d\sigma}{dx} = \frac{2\mu U}{\sigma}$$

$$\text{or } \sigma \cdot \frac{d\sigma}{dx} = \frac{15\mu U}{\rho U^2} = \frac{15\mu}{\rho U^2}$$

$$\text{or } \sigma \cdot d\sigma = \frac{15\mu}{\rho U} dx$$

Integrating both sides, we get

$$\frac{\delta^2}{2} = \frac{15\mu}{\rho U} x + c \quad (\text{where } C = \text{Constant of integration})$$

$$\text{At } x=0, \delta=0 \therefore C=0$$

$$\therefore \frac{\delta^2}{2} = \frac{15\mu}{\rho U} x$$

$$\begin{aligned} \text{or } \delta &= \sqrt{\frac{2 \times 15\mu x}{\rho U}} = 5.48 \sqrt{\frac{\mu x}{\rho U}} \\ &= 5.48 \sqrt{\frac{\mu x \times x}{\rho U \times x}} = 5.48 \sqrt{\frac{x^2}{\text{Re}_x}} \end{aligned}$$

$$\left(\text{where } \text{Re}_x = \frac{\rho U x}{\mu} \right)$$

$$\text{or } \sigma = 5.48 = \frac{x}{\sqrt{\text{Re}_x}} \text{------(v)}$$

(ii) Shear stress τ_o :

From equation (iv), we have

$$\tau_o = \frac{2\mu U}{\sigma}$$

$$\text{But } \sigma = 5.48 \frac{x}{\sqrt{\text{Re}_x}}$$

$$\therefore \tau_o = \frac{2\mu U}{5.48 \frac{x}{\sqrt{\text{Re}_x}}} = \frac{2\mu U \sqrt{\text{Re}_x}}{5.48 x} = 0.365 \frac{\mu U}{x} \sqrt{\text{Re}_x} \text{------(vi)}$$



(iii) Local Co-efficient of drag, C_D^*

$$\tau_o = \frac{0.365 \mu U}{x} = \sqrt{\text{Re}_x}$$

also $\tau_o = C_D^* \frac{\rho U^2}{2}$ -----(vii) (where C_D^* = local coefficient of drag)

Equating the two of τ_o , given by equation (vi) and (vii), we get

$$C_D^* = \frac{0.365 \mu U}{x} \sqrt{\text{Re}_x} \text{ or } C_D^* = 0.365 \times 2 \times \frac{\sqrt{\text{Re}_x}}{\frac{\rho U x}{\mu}}$$

$$= \frac{0.73}{\sqrt{\text{Re}_x}}$$

(iv) Co-efficient of drag, C_D :

We know that $C_D = \frac{F_D}{\frac{1}{2} \rho A U^2}$

Where, $F_D = \int_0^L \tau_o \times B \times dx$

$$= \int_0^L 0.365 \frac{\mu U}{x} \sqrt{\text{Re}_x} \times B \times dx$$

$$= 0.365 \int_0^L \frac{\mu U}{x} \sqrt{\frac{\rho U x}{\mu}} \times B \times dx \left(\because \text{Re}_x = \frac{\rho U x}{\mu} \right)$$

$$= 0.365 \int_0^L \frac{\mu U}{x} \sqrt{\frac{\rho U x}{\mu}} \times \frac{1}{\sqrt{x}} \times B \times dx$$

$$= 0.365 \mu U \sqrt{\frac{\rho U}{\mu}} \times B \int_0^L x^{-\frac{1}{2}} \times dx$$

$$= 0.365 \mu U \sqrt{\frac{\rho U}{\mu}} \times B \left[\frac{x^{-\frac{1}{2}}}{\frac{1}{2}} \right]$$

$$= 0.365 \times 2 \mu U B \sqrt{\frac{\rho U}{\mu}} \times B \sqrt{L}$$



$$\therefore C_D = \frac{0.73\mu UB \sqrt{\frac{\rho U}{\mu}}}{\frac{1}{2}\rho AU^2}$$

(Where A – area of plate = L x B, L and B being length and width of the plate respectively)

$$\begin{aligned} \therefore C_D &= \frac{0.73\mu UB \sqrt{\frac{\ell UL}{\mu}}}{\frac{1}{2}\ell \times L \times B \times U^2} = \frac{1.46\mu}{\ell LU} \sqrt{\frac{\ell UL}{\mu}} \\ &= \frac{1.46\sqrt{\mu}}{\sqrt{\ell LU}} = 1.46\sqrt{\frac{\mu}{\ell LU}} = \frac{1.46}{\sqrt{Re_l}} \end{aligned}$$



5.5 BOUNDARY LAYER SEPARATION AND CONTROL – DRAG ON FLAT PLATE

SEPARATION OF BOUNDARY LAYER

When a solid body is immersed in a flowing fluid, a thin layer of fluid called the boundary layer is formed adjacent to the solid body. In this thin layer of fluid, the velocity varies from zero to free stream velocity in the direction normal to the solid body.

Along the length of the solid body, the thickness of the boundary layer increases. The fluid layer adjacent to the solid surface has to do work against surface friction at the expense of its kinetic energy. This loss of the kinetic energy is recovered from the immediate fluid layer in contact with the layer adjacent to solid surface through momentum exchange process.

Thus the velocity of the layer goes on decreasing. Along the length of the solid body, at a certain point a stage may come when the boundary layer may not be able to keep sticking to the solid body if it cannot provide kinetic energy to overcome the resistance offered by the solid body. In other words, the boundary layer will be separated from the surface. This phenomenon is called the boundary layer separation. The point on the body at which the boundary layer is on the verge of separation from the surface is called point of separation.

Effect of Pressure Gradient on Boundary Layer Separation

The effect of pressure gradient $\left(\frac{dp}{dx}\right)$ on boundary layer separation can be explained by considering the flow over a curved surface ABCSD as shown in the figure below. In the region ABC of the curved surface, the area of flow decreases and hence velocity increases. This means that flow get accelerated in this region. Due to the increase of the velocity, the pressure decreases in the direction of the flow and hence pressure gradient $\frac{dp}{dx}$ is negative in this region. As long as $\frac{dp}{dx} < 0$, the entire boundary layer moves forward as shown.

Region CSD of the curved: the pressure is minimum at the points C. Along the region CSD of the curved surface, the area of flow increases and hence velocity of flow along the direction of fluid decreases. Due to decrease of velocity, the pressure increases in the direction of flow and hence pressure gradient $\frac{dp}{dx}$ is positive or $\frac{dp}{dx} > 0$. Thus in the region CSD, the pressure gradient is positive and velocity of fluid layers along the direction of flow decreases. As earlier mentioned, the velocity of the layer adjacent to the solid surface along the length of the solid surface goes on decreasing as the kinetic energy of the layer is used to overcome the frictional resistance of the surface. Thus the



energy of the layer is used to overcome the frictional resistance of the surface. Thus the combine effect positive pressure gradient and surface resistance reduces the momentum of the fluid. A stage comes, when the momentum of the fluid is unable to overcome the surface resistance and the boundary layer starts separating from the surface at the point S. Downstream the point S, the flow is taking place in reverse direction and the velocity gradient becomes negative.

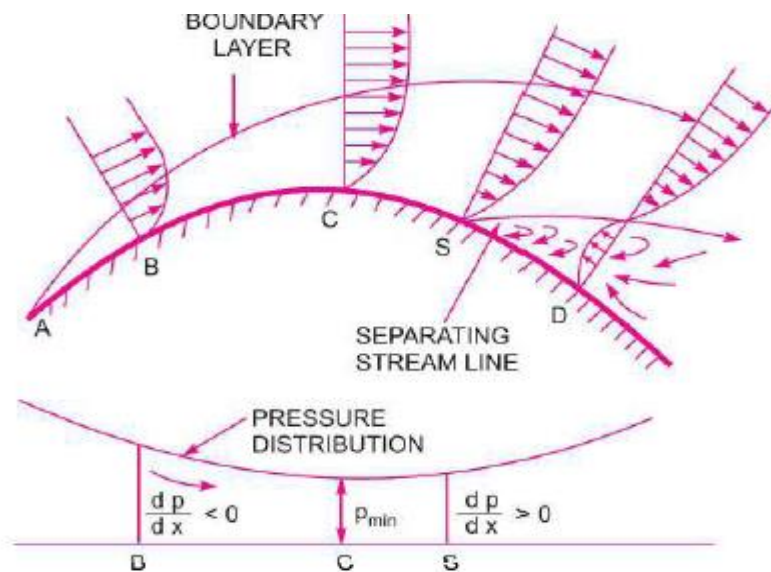

Figure 5.6.1 Effect of pressure gradient on boundary layer separation

[Source: “Fluid Mechanics and Hydraulics Machines” by Dr.R.K.Bansal, Page: 649]

The flow separation depends upon factors such as

- (i) The curvature of the surface
- (ii) The Reynolds number of flow
- (iii) The roughness of the surface

The velocity gradient for a given velocity profile, exhibits the following characteristics for the flow to remain attached, get detached or be on the verge of separation:

1 $\left(\frac{du}{dy}\right)_{y=0}$ is +ve ----- attached flow (the flow will not separate)

2 $\left(\frac{du}{dy}\right)_{y=0}$ is zero ----- The flow is on the verge of separation

3 $\left(\frac{du}{dy}\right)_{y=0}$ is -ve ----- Separated flow



Methods of preventing the Separation of Boundary Layer

The following are some of the methods generally adopted to retard or arrest the flow separation:

1. Streamlining the body shape
2. Tripping the boundary layer from laminar to turbulent by provision of surface roughness
3. Sucking the retarded flow
4. Injecting high velocity fluid in the boundary layer
5. Providing slots near the leading edge
6. Guidance of flow in a confined passage
7. Providing a rotating cylinder near the leading edge
8. Energizing the flow by introducing optimum amount of swirl in the in coming flow

PROBLEM 1: For the following velocity profiles, determine whether the flow is attached or detached or on the verge of separation:

$$\text{i. } \frac{u}{U} = 2\left(\frac{y}{\sigma}\right) - \left(\frac{y}{\sigma}\right)^2 \quad \text{ii. } \frac{u}{U} = 2\left(\frac{y}{\sigma}\right)^2 + \left(\frac{y}{\sigma}\right)^3 + 2\left(\frac{y}{\sigma}\right)^4$$

$$\text{iii. } \frac{u}{U} = 2\left(\frac{y}{\sigma}\right) - \left(\frac{y}{\sigma}\right)^3 + 2\left(\frac{y}{\sigma}\right)^4$$

Solution

$$\text{i. } \frac{u}{U} = 2\left(\frac{y}{\sigma}\right) - \left(\frac{y}{\sigma}\right)^2 \text{ or } U = 2U\left(\frac{y}{\sigma}\right) - U\left(\frac{y}{\sigma}\right)^2$$

Differentiating w.r.t.y the above equation, we get

$$\frac{du}{dy} = 2U\left(\frac{1}{\sigma}\right) - 2U\left(\frac{y}{\sigma}\right) \times \frac{1}{\sigma}$$

$$\text{At } y = 0, \left(\frac{du}{dy}\right)_{y=0} = \frac{2U}{\sigma}$$

As $\left(\frac{du}{dy}\right)_{y=0}$ is +ve, the given flow is attached



$$\text{ii. } \frac{u}{U} = 2\left(\frac{y}{\sigma}\right) + \left(\frac{y}{\sigma}\right)^3 + 2\left(\frac{y}{\sigma}\right)^4$$

$$\text{or } u = -2U\left(\frac{y}{\sigma}\right) + \left(\frac{y}{\sigma}\right)^3 + U\left(\frac{y}{\sigma}\right)^3 + 2U\left(\frac{y}{\sigma}\right)^4$$

$$\frac{du}{dy} = 2U\left(\frac{1}{\sigma}\right) - 3U\left(\frac{y}{\sigma}\right)^2 \times \frac{1}{\sigma} + 8U\left(\frac{y}{\sigma}\right)^3 \times \frac{1}{\sigma}$$

$$\text{At } y = 0, \left(\frac{du}{dy}\right)_{y=0} = \frac{2U}{\sigma}$$

As $\left(\frac{du}{dy}\right)_{y=0}$ is +ve, the given flow is attached (i.e. the flow has separated)

$$\text{iii. } \frac{u}{U} = \left(\frac{y}{\sigma}\right)^2 + \left(\frac{y}{\sigma}\right)^3 + 2\left(\frac{y}{\sigma}\right)^4$$

$$\text{Or } u = -2U\left(\frac{y}{\sigma}\right)^2 + \left(\frac{y}{\sigma}\right)^3 - 2U\left(\frac{y}{\sigma}\right)^4$$

$$\therefore \frac{du}{dy} = 4U\left(\frac{y}{\sigma}\right) \times \frac{1}{y} + 3U\left(\frac{y}{\sigma}\right) \times \frac{1}{\sigma} - 8U\left(\frac{y}{\sigma}\right)^3 \times \frac{1}{\sigma}$$

$$\text{At } y = 0, \left(\frac{du}{dy}\right)_{y=0} = 0$$

As $\left(\frac{du}{dy}\right)_{y=0} = 0$, the given flow is on the verge of separation